

# MOUNTING AND OPERATING INSTRUCTIONS

**SAMSON**

## **EB 3017 EN**

**Translation of original instructions**



**Type 42-37 Flow and Differential Pressure Regulator**  
**Type 42-39 Flow and Differential Pressure or Pressure Regulator**  
Self-operated Regulators

Edition December 2025

**CE**

## Note on these mounting and operating instructions

These mounting and operating instructions assist you in mounting and operating the device safely. The instructions are binding for handling SAMSON devices. The images shown in these instructions are for illustration purposes only. The actual product may vary.

- For the safe and proper use of these instructions, read them carefully and keep them for later reference.
- If you have any questions about these instructions, contact SAMSON's After-sales Service (aftersalesservice@samsongroup.com).



Documents relating to the device, such as the mounting and operating instructions, are available on our website at [www.samsongroup.com](http://www.samsongroup.com) > **DOWNLOADS** > **Documentation**.

## Definition of signal words

### **DANGER**

*Hazardous situations which, if not avoided, will result in death or serious injury*

### **WARNING**

*Hazardous situations which, if not avoided, could result in death or serious injury*

### **NOTICE**

*Property damage message or malfunction*

### **Note**

*Additional information*

### **Tip**

*Recommended action*

<b>1</b>	<b>Safety instructions and measures .....</b>	<b>1-1</b>
1.1	Notes on possible severe personal injury.....	1-5
1.2	Notes on possible personal injury .....	1-5
1.3	Notes on possible property damage .....	1-8
<b>2</b>	<b>Markings on the device .....</b>	<b>2-1</b>
2.1	Nameplates.....	2-1
2.2	Location of the nameplates .....	2-2
2.3	Material identification number .....	2-2
2.3.1	Type 2423 Valve.....	2-2
2.3.2	Type 2427 and Type 2429 Actuators .....	2-2
<b>3</b>	<b>Design and principle of operation.....</b>	<b>3-1</b>
3.1	Additional fittings.....	3-6
3.2	Technical data.....	3-8
<b>4</b>	<b>Shipment and on-site transport .....</b>	<b>4-1</b>
4.1	Accepting the delivered goods .....	4-1
4.2	Removing the packaging from the regulator.....	4-1
4.3	Transporting and lifting the regulator.....	4-2
4.3.1	Transporting the regulator .....	4-2
4.3.2	Lifting the regulator .....	4-3
4.4	Storing the regulator .....	4-4
<b>5</b>	<b>Installation.....</b>	<b>5-1</b>
5.1	Installation conditions .....	5-1
5.2	Preparation for installation.....	5-5
5.3	Installation .....	5-6
5.3.1	Installing the regulator .....	5-8
5.4	Testing the regulator .....	5-9
5.4.1	Leak test .....	5-9
5.4.2	Pressure test.....	5-10
5.4.3	Filling the plant.....	5-11
5.4.4	Cleaning the pipeline.....	5-12
5.5	Insulation .....	5-12
<b>6</b>	<b>Start-up.....</b>	<b>6-1</b>
6.1	Start-up and putting the device back into operation .....	6-2
6.2	Starting up the plant.....	6-2
6.2.1	Control applications with liquids.....	6-3
6.2.2	Control applications with steam .....	6-3

# Contents

<b>7</b>	<b>Operation .....</b>	<b>7-1</b>
7.1	Adjusting the set point .....	7-1
7.2	Adjusting the flow set point .....	7-2
7.3	Adjusting the differential pressure set point of the Type 2427 Actuator (Type 42-37) .....	7-12
7.4	Adjusting the pressure set point of the Type 2429 Actuator (Type 42-39) ...	7-12
<b>8</b>	<b>Malfunctions .....</b>	<b>8-1</b>
8.1	Troubleshooting .....	8-1
8.2	Emergency action .....	8-3
<b>9</b>	<b>Servicing .....</b>	<b>9-1</b>
9.1	Service work preparations .....	9-6
9.2	Installing the regulator after service work .....	9-6
9.3	Service work .....	9-6
9.3.1	Replacing the actuator .....	9-7
9.3.2	Replacing the seat and plug .....	9-7
9.3.3	Replacing the actuator's operating diaphragm .....	9-7
9.4	Ordering spare parts and operating supplies .....	9-8
<b>10</b>	<b>Decommissioning .....</b>	<b>10-1</b>
<b>11</b>	<b>Removal .....</b>	<b>11-1</b>
11.1	Removing the regulator from the pipeline .....	11-1
11.2	Removing the actuator from the valve .....	11-1
<b>12</b>	<b>Repairs .....</b>	<b>12-1</b>
12.1	Returning devices to SAMSON .....	12-1
<b>13</b>	<b>Disposal .....</b>	<b>13-1</b>
<b>14</b>	<b>Certificates .....</b>	<b>14-1</b>
<b>15</b>	<b>Appendix .....</b>	<b>15-1</b>
15.1	Tightening torques .....	15-1
15.2	Lubricants .....	15-1
15.3	Tools .....	15-1
15.4	Accessories .....	15-1
15.5	Spare parts .....	15-2
15.6	After-sales service .....	15-9

# 1 Safety instructions and measures

## Intended use

The SAMSON Type 42-37 Regulator is a flow and differential pressure regulator. The SAMSON Type 42-39 Regulator is a flow and differential pressure or pressure regulator.

They consist of a Type 2423 Valve and a Type 2427 Actuator (Type 42-37) or a Type 2429 Actuator (Type 42-39). The valve and actuator (except for tested regulators) are delivered separately and must be assembled together according to this document.

The self-operated regulators are used to control the flow rate and the differential pressure or pressure in pipelines. Liquids, gases and vapors in district heating systems as well as processing and industrial plants can be controlled by the regulator. The regulators are designed to operate under exactly defined conditions (e.g. operating pressure, process medium, temperature). Therefore, operators must ensure that the regulators are only used in operating conditions that meet the specifications used for sizing the devices at the ordering stage. In case operators intend to use the regulators in applications or conditions other than those specified, contact SAMSON.

SAMSON does not assume any liability for damage resulting from the failure to use the device for its intended purpose or for damage caused by external forces or any other external factors.

➔ Refer to the technical data and nameplate for limits and fields of application as well as possible uses.

## Reasonably foreseeable misuse

The regulators are not suitable for the following applications:

- Use outside the limits defined during sizing and by the technical data
- Use outside the limits defined by the additional fittings mounted on the regulator

Furthermore, the following activities do not comply with the intended use:

- Use of non-original spare parts
- Performing service and repair work not described

## Safety instructions and measures

### Qualifications of operating personnel

The regulator must be mounted, started up, serviced and repaired by fully trained and qualified personnel only; the accepted industry codes and practices must be observed. According to these mounting and operating instructions, trained personnel refers to individuals who are able to judge the work they are assigned to and recognize possible hazards due to their specialized training, their knowledge and experience as well as their knowledge of the applicable standards.

### Personal protective equipment

SAMSON recommends checking the hazards posed by the process medium being used (e.g. ► GESTIS (CLP) hazardous substances database). Depending on the process medium and/or the activity, the protective equipment required includes:

- Protective clothing, safety gloves and eye protection in applications with hot, cold and/or corrosive media
- Wear hearing protection when working near the valve. Follow the instructions given by the plant operator.
- Hard hat
- Safety harness, e.g. when working at height
- Safety footwear, if applicable ESD (electrostatic discharge) footwear

➔ Check with the plant operator for details on further protective equipment.

### Revisions and other modifications

Revisions, conversions or other modifications of the product are not authorized by SAMSON. They are performed at the user's own risk and may lead to safety hazards, for example. Furthermore, the product may no longer meet the requirements for its intended use.

### Warning against residual hazards

To avoid personal injury or property damage, plant operators and operating personnel must prevent hazards that could be caused in the regulator by the process medium, the operating pressure or by moving parts by taking appropriate precautions. Plant operators and operating personnel must observe all hazard statements, warnings and caution notes in these mounting and operating instructions.

Hazards resulting from the special working conditions at the installation site of the regulator must be identified in a risk assessment and prevented through the corresponding standard operating procedures drawn up by the operator.

SAMSON also recommends checking the hazards posed by the process medium being used (e.g. ► GESTIS (CLP) hazardous substances database).

→ Observe safety measures for handling the device as well as fire prevention and explosion protection measures.

These mounting and operating instructions deal with the standard version of the device. Components of the device that differ to those used for the standard version described in this document can be exchanged with other certain SAMSON components. The residual hazards of these components are described in the associated mounting and operating instructions (see section 'Referenced documents').

### **Safety features**

The Types 42-37 and 42-39 Regulators do not have any special safety features. When relieved of pressure, the regulators are opened by the force of the set point springs.

### **Responsibilities of the operator**

Operators are responsible for proper use and compliance with the safety regulations. Operators are obliged to provide these mounting and operating instructions as well as the referenced documents to the operating personnel and to instruct them in proper operation. Furthermore, operators must ensure that operating personnel or third parties are not exposed to any danger.

Operators are additionally responsible for ensuring that the limits for the product defined in the technical data are observed. This also applies to the start-up and shutdown procedures. Start-up and shutdown procedures fall within the scope of the operator's duties and, as such, are not part of these mounting and operating instructions. SAMSON is unable to make any statements about these procedures since the operative details (e.g. differential pressures and temperatures) vary in each individual case and are only known to the operator.

### **Responsibilities of operating personnel**

Operating personnel must read and understand these mounting and operating instructions as well as the referenced documents and observe the specified hazard statements, warnings and caution notes. Furthermore, operating personnel must be familiar with the applicable health, safety and accident prevention regulations and comply with them.

## Safety instructions and measures

### Referenced standards, directives and regulations

The regulators comply with the requirements of the European Pressure Equipment Directive 2014/68/EU and the Machinery Directive 2006/42/EC. Regulators with a CE marking have a declaration of conformity which includes information about the applied conformity assessment procedure. The declaration of conformity is included in the 'Certificates' chapter.

According to the ignition hazard assessment performed in accordance with Clause 5.2 of ISO 80079-36, the non-electrical regulators do not have their own potential ignition source even in the rare incident of an operating fault. As a result, they do not fall within the scope of Directive 2014/34/EU.

➔ For connection to the equipotential bonding system, observe the requirements specified in Clause 6.4 of EN 60079-14 (VDE 0165-1).

### Referenced documents

The following documents apply in addition to these mounting and operating instructions:

- Mounting and operating instructions for  
e.g. **Type 2 N or 2 NI Strainer** ▶ EB 1015
- Data sheets for  
e.g. **Accessories · Differential pressure and flow regulators** ▶ T 3095

---

- e.g. **Type 2 N or 2 NI Strainer** ▶ T 1015
- Mounting and operating instructions as well as data sheets for additional fittings (e.g. shut-off valves, pressure gauges etc.).



## 1.1 Notes on possible severe personal injury

### DANGER

#### **Risk of bursting in pressure equipment.**

Regulators and pipelines are pressure equipment. Impermissible pressure or improper opening of the pressure equipment can lead to regulator components bursting.

- Observe the maximum permissible pressure for regulator and plant.
- If necessary, a suitable overpressure protection must be installed on site in the plant section.
- Before starting any work on the regulator, depressurize all plant sections affected as well as the regulator.
- Drain the process medium from the plant sections affected as well as from the regulator.
- Wear personal protective equipment.

## 1.2 Notes on possible personal injury

### WARNING

#### **Crush hazard arising from moving parts.**

The regulator contains moving parts (set point springs), which can injure hands or fingers if inserted into the regulator.

- Do not insert hands or fingers between the set point springs while the regulator is in operation.
- Before performing any work on the regulator, depressurize the plant. Disconnect or shut off the control line.

### **WARNING**

#### **Risk of personal injury due to pressurized components and as a result of process medium being discharged.**

Incorrect opening of pressure equipment or mounting parts may lead to the process medium escaping to the atmosphere.

- Do not unscrew the control line while the valve is pressurized.
- Do not start up the regulator until all parts have been mounted.

#### **Risk of personal injury due to loaded springs.**

The set point springs of regulators with adjusted set point are preloaded and are under tension.

- Before starting any work on the springs, relieve the compression from the preloaded springs.

#### **Risk of hearing loss or deafness due to loud noise.**

The noise emissions depend on the valve version, plant facilities and process medium.

- Wear hearing protection when working near the valve. Follow the instructions given by the plant operator.

#### **Risk of personal injury due to residual process medium in the regulator.**

While working on the regulator, residual process medium can escape and, depending on its properties, may lead to personal injury, e.g. (chemical) burns.

- If possible, drain the process medium from the plant sections affected and from the regulator.
- Wear protective clothing, safety gloves and eye protection.

#### **Risk of burn injuries due to hot or cold components and pipelines.**

Depending on the process medium, regulator components and pipelines may get very hot or cold and cause burn injuries.

- Allow components and pipelines to cool down or warm up to the ambient temperature.
- Wear protective clothing and safety gloves.

### **WARNING**

#### **Damage to health relating to the REACH regulation.**

If a SAMSON device contains a substance listed as a substance of very high concern on the candidate list of the REACH regulation, this is indicated on the SAMSON delivery note.

- Information on the safe use of the part affected. ► <https://www.samsongroup.com/en/about-samson/environment-social-governance/material-compliance/reach-regulation/>

#### **Risk of personal injury due to process medium escaping after an operating diaphragm/bellows rupture.**

When using the Type 42-39 Regulator as a pressure regulator, residual process medium can escape after a rupture of the operating diaphragm and, depending on its properties, lead to personal injury, e.g. (chemical) burns.

- Depressurize plant sections concerned.
- Wear protective clothing, safety gloves and eye protection.

#### **Risk of personal injury due to incorrect operation, use or installation as a result of information on the regulator being illegible.**

Over time, markings, labels and nameplates on the regulator may become covered with dirt or become illegible in some other way. As a result, hazards may go unnoticed and the necessary instructions not followed. There is a risk of personal injury.

- Keep all relevant markings and inscriptions on the device in a constantly legible state.
- Immediately renew damaged, missing or incorrect nameplates or labels.

## 1.3 Notes on possible property damage

### ! NOTICE

#### **Risk of regulator damage due to incorrectly attached slings.**

- Do not attach load-bearing slings to the actuator housing (see section 'Lifting the regulator' in the 'Shipment and on-site transport' chapter).

#### **Risk of regulator damage due to unsuitable medium properties.**

The regulator is designed for a process medium with defined properties.

- Only use the process medium specified for sizing the device.

#### **Risk of regulator damage due to contamination (e.g. solid particles) in the pipeline.**

The plant operator is responsible for cleaning the pipelines in the plant.

- Flush the pipelines before start-up.

#### **Risk of regulator damage due to the use of unsuitable lubricants.**

The lubricants to be used depend on the regulator material. Unsuitable lubricants may corrode and damage surfaces.

- Only use lubricants approved by SAMSON.  
When in doubt, consult SAMSON.

#### **Risk of regulator damage due to the use of unsuitable tools.**

Certain tools are required to work on the regulator.

- Only use tools approved by SAMSON.  
When in doubt, consult SAMSON.

#### **Risk of the process medium being contaminated through the use of unsuitable lubricants and/or contaminated tools and components.**

- Keep the regulator and the tools used free from solvents and grease.
- Make sure that only suitable lubricants are used.

### ! NOTICE

#### **Risk of leakage and regulator damage due to over- or under-torquing.**

Observe the specified torques when tightening regulator components. Excessive tightening torques lead to parts wearing out more quickly. Parts that are too loose may cause leakage.

- Observe the specified tightening torques (see the 'Tightening torques' chapter in the Appendix).

#### **Risk of excess pressure damaging plant sections due to construction-related seat leakage through the regulator.**

- Always install a safety device (e.g. safety excess pressure valve or safety relief valve) in the plant.

#### **Incorrect control due to the formation of ice on the regulator.**

Medium temperatures below 0 °C may cause ice to form on the regulator, depending on the air humidity. This may affect, in particular, the functioning of the plug or diaphragm stem guide.

- Prevent the formation of ice by taking appropriate precautions (e.g. enclosure, trace heater etc.). The plant operator is responsible for selecting and implementing appropriate precautions (see the 'Installation' chapter).

#### **Risk of damage due to process medium escaping after an operating diaphragm rupture.**

When using the Type 42-39 Regulator as a pressure regulator, residual process medium can escape after a rupture of the operating diaphragm and, depending on its properties, lead to device damage or peripheral damage.

- When a regulator is fitted with a leakage line connection, discharge any vapors or gases that escape through a leakage line to the atmosphere and in a safe place.
- Catch any liquids or gases that escape and may be harmful to the environment in a tank. Dispose of them in accordance with the applicable regulations.

**!** NOTICE

---

**i** Note

*SAMSON's After-sales Service can support you concerning lubricant, tightening torques and tools approved by SAMSON.*

---

## 2 Markings on the device

Several nameplates are affixed to the device. The nameplates shown were up to date at the time of publication of this document. The nameplates on the de-

vice may differ from the ones shown. The nameplates are used to identify the separate regulator components (see Chapter 2.1).

### 2.1 Nameplates

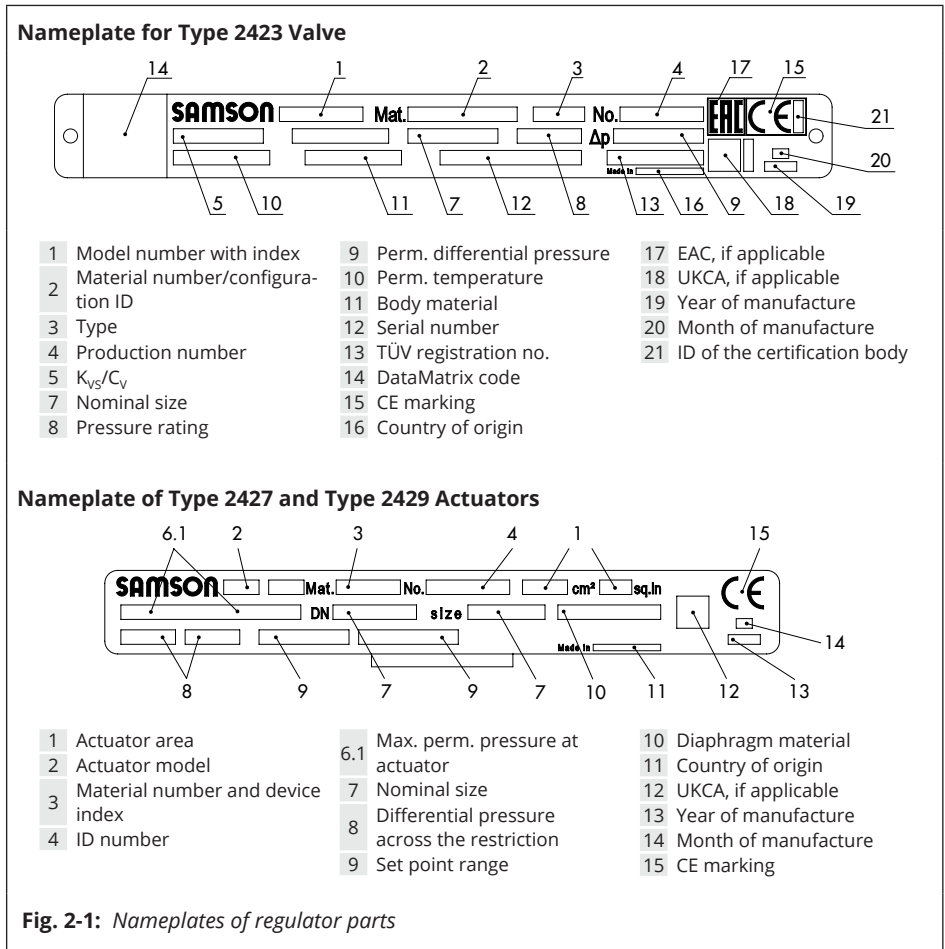
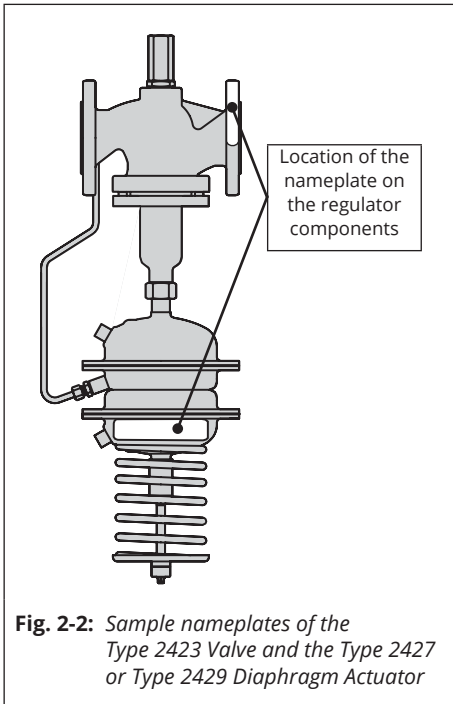


Fig. 2-1: Nameplates of regulator parts

## 2.2 Location of the nameplates



**Fig. 2-2:** *Sample nameplates of the Type 2423 Valve and the Type 2427 or Type 2429 Diaphragm Actuator*

## 2.3 Material identification number

### 2.3.1 Type 2423 Valve

The material is specified in the 'Body material' field (DIN/ANSI, item 11). For more details on the nameplate, see Chapter 2.1.

### 2.3.2 Type 2427 and Type 2429 Actuators

Specifying the material number, you can contact SAMSON to find out which material is used. It is specified on the nameplate in the 'MNo.' field (3 for DIN/ANSI). For more details on the nameplate, see Chapter 2.1.



### 3 Design and principle of operation

→ See Fig. 3-1 to Fig. 3-3

The regulators restrict the flow rate in the pipeline to a set point adjusted at the restriction. The set point for the differential pressure or downstream pressure is adjusted at the diaphragm actuator. The largest signal is always used to control the regulator.

The regulators basically consist of a Type 2423 Valve with seat, plug and restriction as well as a closing actuator (Type 2427 or Type 2429) with an operating diaphragm. Valve and actuator are delivered separately and must be assembled on site using a coupling nut.

The medium flows through the valve in the direction indicated by the arrow. The areas released by the restriction (1.1) and the plug (3) determine the flow rate and the differential pressure  $\Delta p$  across the plant.

In balanced valves, the forces acting on the plug created by the upstream and downstream pressures are balanced by a balancing bellows (5) or balancing diaphragm (5.1, balanced by a diaphragm, DN 65 to 250).

Regulators balanced by a bellows or a diaphragm only differ in the pressure balancing principle applied. Valves balanced by a diaphragm have a balancing diaphragm (5.1) instead of the balancing bellows (5). The downstream pressure  $p_2$  acts on the bottom of the diaphragm

and the upstream pressure  $p_1$  on the top of the diaphragm. In both cases, the forces created by the upstream and downstream pressures that act on the plug are balanced out.

**Type 42-37:** The high pressure of  $\Delta p$  acts on the bottom diaphragm chamber **D** over the control line (18). The high pressure of the flow rate upstream of the restriction (1.1) is transferred over the control line (19) to the middle diaphragm chamber **B** and **C**. It is the same as the low pressure of  $\Delta p$ . The low pressure of  $\dot{V}$  downstream of the restriction is transferred over holes in the plug and diaphragm stems to the top diaphragm chamber **A**.

For example, if the differential pressure rises, the resulting positioning force at the bottom operating diaphragm (13.2) rises as well. The diaphragm stems (12.1 and 12.2) push the plug stem with plug in the closing direction until the flow rate reaches the set point adjusted at the set point spring (16).

If the flow rate increases, the differential pressure at the restriction (1.1) and the resulting positioning force at the top operating diaphragm (13.1) increase. The top diaphragm stem (12.1) pushes the plug stem with plug in the closing direction until the flow rate reaches the adjusted flow set point. The largest signal is always used to move the plug.

## Design and principle of operation

An overload protection (force limiter with internal excess pressure limiter) (15) protects the seat (2), plug (3) and plant from overload during exceptional operating conditions.

**Type 42-39:** The principle of operation is almost the same as for Type 42-37. However, in the Type 2429 Actuator, the high pressure of the flow rate is separate from the low pressure of the differential pressure  $\Delta p$ . The diaphragm chambers have their own control line connections.

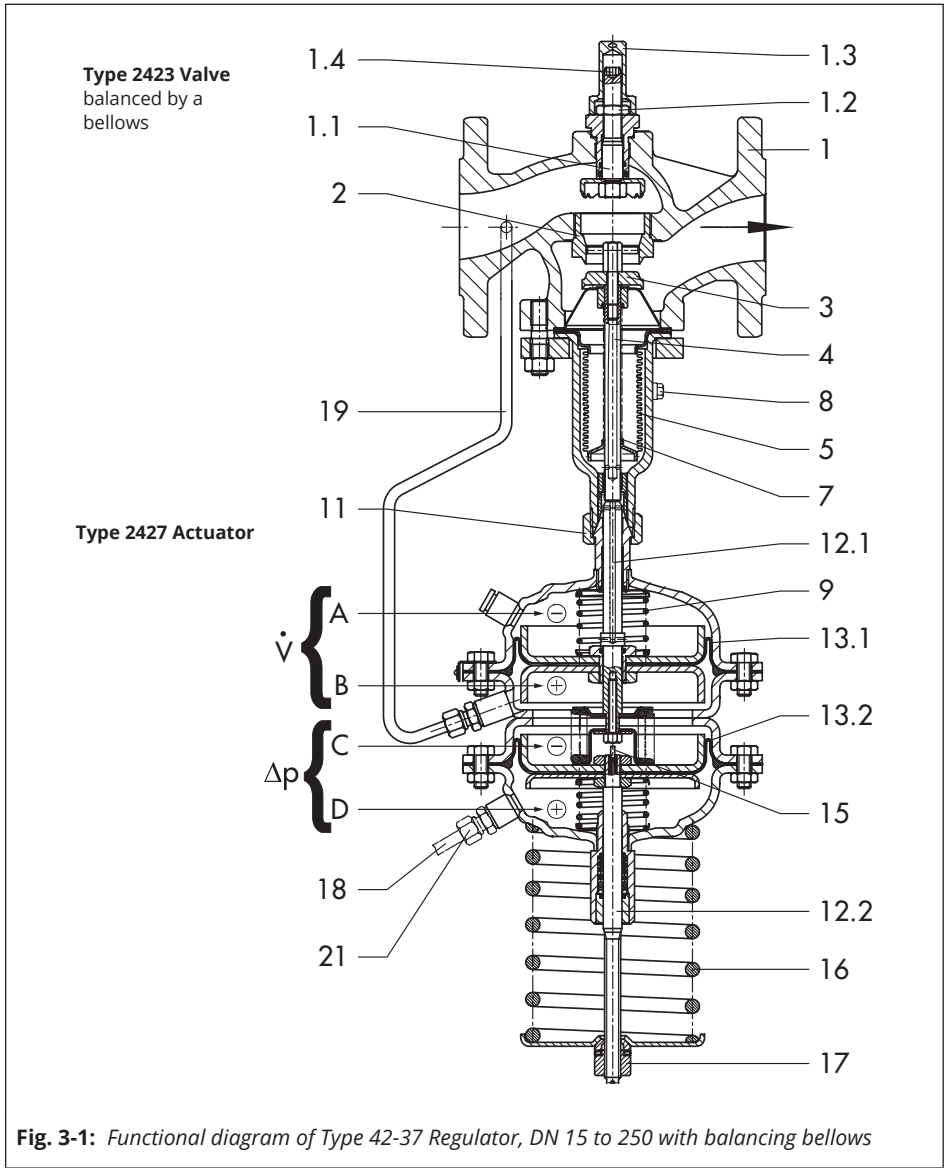
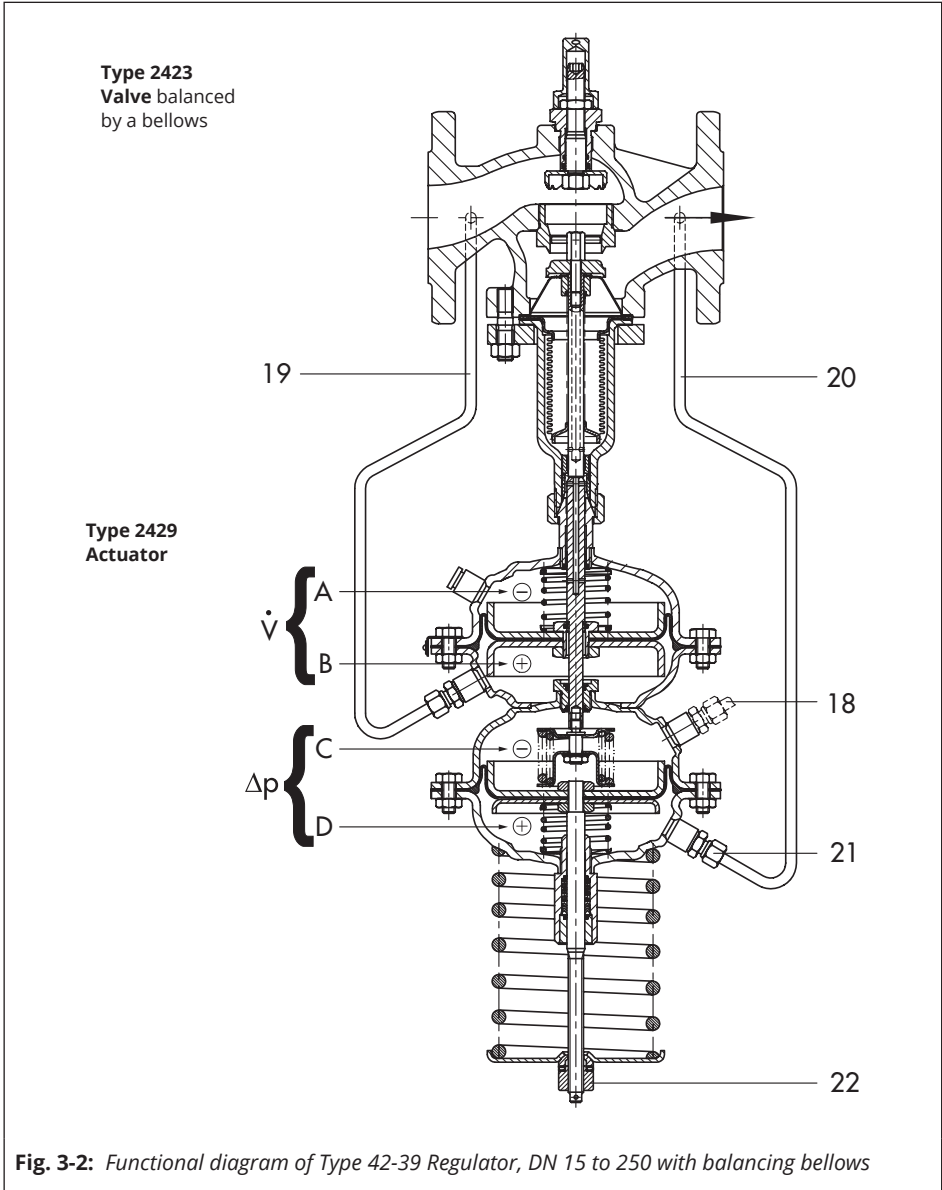
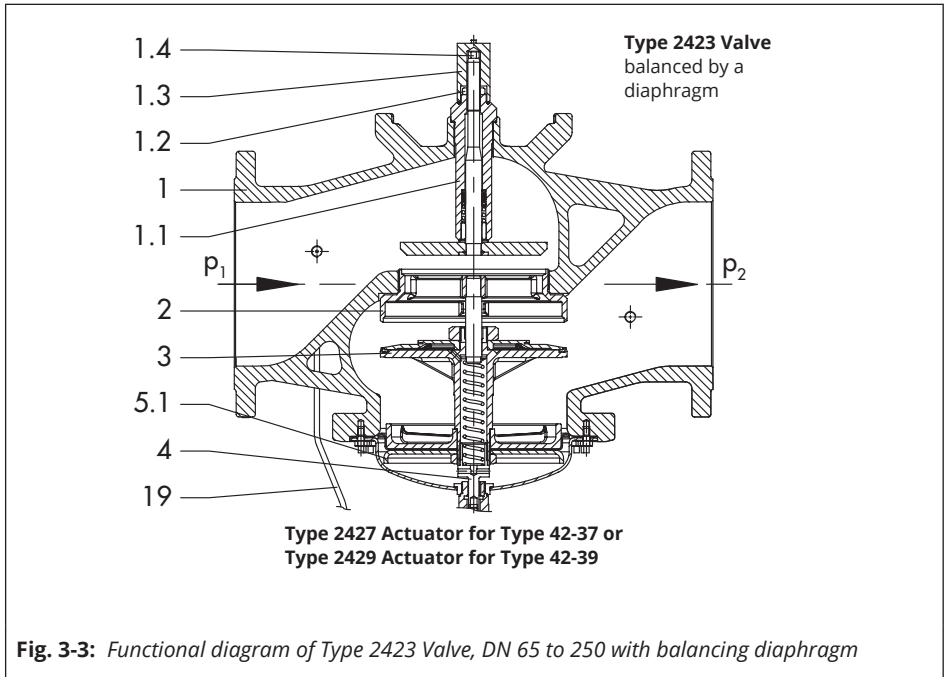


Fig. 3-1: Functional diagram of Type 42-37 Regulator, DN 15 to 250 with balancing bellows

## Design and principle of operation





**Fig. 3-3:** Functional diagram of Type 2423 Valve, DN 65 to 250 with balancing diaphragm

Legend for Fig. 3-1 to Fig. 3-3

1	Valve body	13.1	Top operating diaphragm
1.1	Restriction	13.2	Bottom operating diaphragm
1.2	Lock nut	15	Overload protection
1.3	Cap	16	Set point spring
1.4	Set point adjuster for flow rate	17	Set point adjuster (differential pressure)
2	Seat	18	Control line (to be provided on site)
3	Plug	19	Control line (+) $\dot{V}$
4	Plug stem	20	Control line (+) $\Delta p$
5	Balancing bellows	21	Restriction to dampen signal
5.1	Balancing diaphragm	22	Set point adjuster (pressure)
7	Spring		
8	Vent plug (DN 125 and larger)		
9	Differential pressure spring		
11	Coupling nut		
12.1	Top diaphragm stem		
12.2	Bottom diaphragm stem		

### 3.1 Additional fittings

→ See Fig. 3-4

#### Pressure gauges

Install a pressure gauge (3 and 6) at suitable points to monitor the pressures prevailing in the plant.

#### Bypass line and shut-off valves

SAMSON recommends installing a shut-off valve (1 and 9) both upstream of the strainer and downstream of the regulator to ensure that the entire plant does not need to be shut down for service or repair work. An optional bypass (7) can be used to achieve the maximum flow rate during regulator start-up when adjusting the flow set point.

#### Strainers

SAMSON recommends installing a SAMSON strainer (2) upstream of the valve. It prevents solid particles in the process medium from damaging the regulator.

- Do not use the strainer to permanently filter the process medium.
- Select a strainer (mesh size) suitable for the process medium.

---

#### **i** Note

*Any impurities carried along by the process medium may impair the proper functioning of the regulator. SAMSON recommends installing a strainer (e.g. SAMSON Type 2 NI) upstream of the valve (▶ EB 1015).*

---

#### Insulation

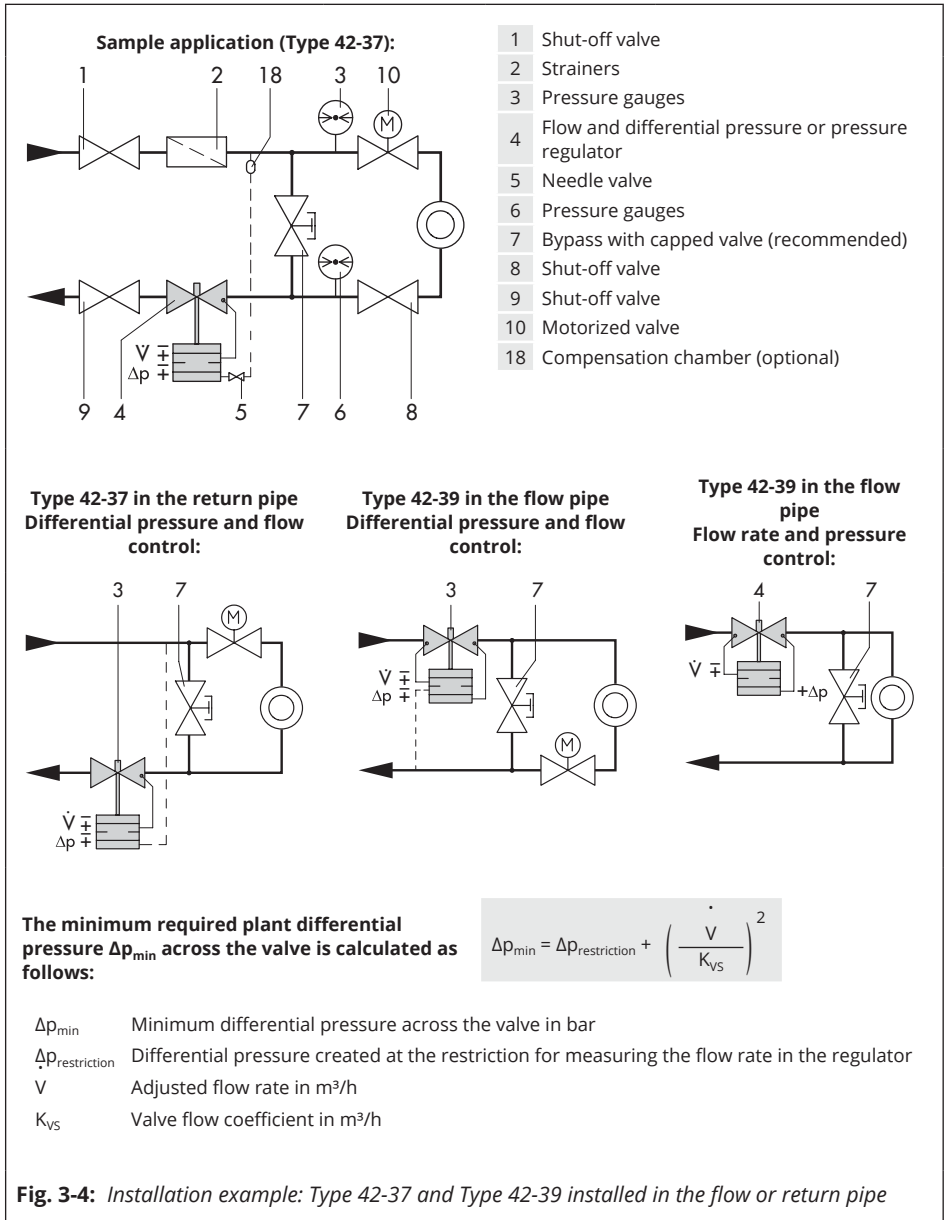
Regulators can be insulated to reduce heat energy transfer. Refer to the instructions in the 'Installation' chapter.

---

#### **i** Note

*The Type 42-37 and Type 42-39 Regulators are not safety valves. If necessary, a suitable overpressure protection must be installed on site in the plant section.*

---



### 3.2 Technical data

The valve and actuator nameplates provide information on the valve and actuator versions (see the 'Markings on the device' chapter).

#### **i Note**

More information is available in Data Sheet ► T 3017.

#### Conformity

The Types 42-37 and 42-39 Regulators bear the CE mark of conformity.



#### Process medium and scope of application

The Type 42-37 and Type 42-39 Flow and Differential Pressure or Pressure Regulators are designed to maintain the flow rate and differential pressure or pressure in a plant to an adjusted set point.

The Type 42-37 Regulator can be used in district heating systems. The Type 42-39 Regulator can be used in district heating systems as well as industrial applications.

- Suitable for liquids, max. temperature 150 °C · 220 °C<sup>1)</sup>
- Suitable for vapors, max. temperature 220 °C<sup>2)</sup>
- Suitable for gases, max. temperature 80 °C
- Differential pressure or pressure set points from 0.1 to 10 bar
- Flow rate set points from 0.05 to 520 m<sup>3</sup>/h
- Nominal size DN 15 to 250
- Pressure rating PN 16 to 40

The regulator is open when relieved of pressure. The valve **closes** when the differential pressure/pressure or flow rate **rises**.

#### Leakage class

The metal-seated regulator has the leakage class I according to IEC 60534-4. The soft-seated regulator has the leakage class IV according to IEC 60534-4.

#### Temperature range

Depending on how the regulator is configured and the process medium used, it can be used up to temperatures of 220 °C (see Table 3-1). The minimum temperature is limited by the accessories used and the actuator's diaphragm material (► T 3017).

#### Noise emissions

SAMSON is unable to make general statements about noise emissions. The noise emissions depend on the regulator version, plant facilities, process medium and operating conditions.

<sup>1)</sup> With compensation chamber



<sup>2)</sup> Type 42-39 only with compensation chamber



**Dimensions and weights**

Table 3-4 and Table 3-5 provide an overview of the dimensions and weights. The lengths and heights in the dimensional drawings are shown on page 3-13.

**Table 3-1: Technical data · Types 42-37 and 42-39 · All pressures in bar (gauge)**

<b>Type 2423 Valve · Balanced by a bellows</b>		
<b>Nominal size</b>		<b>DN 15 to 250</b>
Pressure rating		PN 16, 25 or 40
Pressure at which internal excess pressure limiter responds (Type 42-37 only)	160 cm <sup>2</sup>	1.2 bar
	320 cm <sup>2</sup>	0.6 bar
Max. permissible temperature	Valve body	See pressure-temperature diagram in ► T 3000
	Actuator <sup>1)</sup>	With compensation chamber: liquids up to 220 °C Without compensation chamber: 150 °C
Differential pressure or pressure set point ranges		0.1 to 0.6 bar · 0.2 to 1 bar · 0.5 to 1.5 bar · 1 to 2.5 bar 2 to 5 bar <sup>2)</sup> · 4.5 to 10 bar <sup>2)</sup>
Leakage class according to IEC 60534-4		≤0.05 % of K <sub>VS</sub> coefficient
Conformity		
<b>Type 2423 Valve · Balanced by a diaphragm</b>		
<b>Nominal size</b>		<b>DN 65 to 250</b>
Pressure rating		PN 16, 25 or 40
Pressure at which internal excess pressure limiter responds (Type 42-37 only)	160 cm <sup>2</sup>	1.2 bar
	320 cm <sup>2</sup>	0.6 bar
Max. permissible temperature	Valve body	150 °C
	Actuator <sup>1)</sup>	Liquids 150 °C
Differential pressure or pressure set point ranges		0.1 to 0.6 bar · 0.2 to 1 bar · 0.5 to 1.5 bar · 1 to 2.5 bar · 2 to 5 bar <sup>2)</sup>
Leakage class according to IEC 60534-4		≤0.05 % of K <sub>VS</sub> coefficient
Conformity		

<sup>1)</sup> Higher temperatures on request

<sup>2)</sup> On request

## Design and principle of operation

**Table 3-2:**  $K_{VS}$  coefficients,  $x_{FZ}$  values, flow rate set point ranges for water and max. permissible differential pressures  $\Delta p$

Type 2423 Valve balanced by a bellows														
Nominal size DN	15	20	25	32	40	50	65	80	100	125	150	200	250	
Valve travel	10 mm						16 mm			22 mm				
$K_{VS}$ coefficient	4	6.3	8	16	20	32	50	80	125	190	280	420	500	
$x_{FZ}$ value	0.65	0.6	0.55		0.45	0.4		0.35				0.3		
Flow rate set point ranges for water in m <sup>3</sup> /h														
Diff. pres- sure across restriction $\Delta p_{restriction}$	0.2 bar	0.05 to 2	0.15 to 3	0.25 to 3.5	0.4 to 7	0.6 to 11	0.9 to 16	2 to 28	3.5 to 35 <sup>1)</sup>	6.5 to 63	11 to 80	18 to 120	20 to 180	26 to 220
	0.5 bar	0.15 to 3	0.25 to 4.5	0.4 to 5.3	0.6 to 9.5	0.9 to 16	2 to 24	3.5 to 40	6.5 to 55	11 to 90	18 to 120	20 to 180	26 to 260	30 to 300
Max. perm. differential pressure $\Delta p$	25 bar						20 bar		16 bar		12 bar	10 bar		
Type 2423 Valve balanced by a diaphragm														
Nominal size DN	65	80	100		125		150	200		250				
Valve travel	15 mm						35 mm							
$K_{VS}$ coefficient	50	80	125		250		380	650		800				
$x_{FZ}$ value	0.4		0.35						0.3					
Flow rate set point ranges for water in m <sup>3</sup> /h														
Diff. pres- sure across restriction $\Delta p_{restriction}$	0.2 bar	2 to 28	3.5 to 35 <sup>1)</sup>		6.5 to 63		11 to 120		18 to 180		20 to 320		26 to 350	
	0.5 bar	3.5 to 40	6.5 to 55		11 to 90		18 to 180		20 to 260		26 to 450		30 to 520	
Max. perm. differential pressure $\Delta p$	12 bar			10 bar		12 bar			10 bar					

<sup>1)</sup> 7 to 35 m<sup>3</sup>/h (160 cm<sup>2</sup> actuator), 7 to 40 m<sup>3</sup>/h (320 cm<sup>2</sup> actuator)

**Table 3-3: Materials · Material numbers according to DIN EN**

<b>Type 2423 Valve · Balanced by a bellows</b>					
Pressure rating	PN 16	PN 25	PN 16, 25 and 40		
Valve body	Cast iron EN-GJL-250	Spheroidal graphite iron EN-GJS-400-18-LT	Cast steel 1.0619	Cast stainless steel 1.4408	Forged stainless steel 1.4404 <sup>1)</sup>
Seat	1.4104, 1.4006			1.4404	
Plug	Up to DN 100	1.4104, 1.4006			1.4404
	DN 125 to 250	1.4301, 1.4404 with PTFE seal			
Plug stem	1.4301				
Metal bellows	1.4571 · DN 125 and larger: 1.4404				
Bottom section	P265GH			1.4571	
Body gasket	Graphite on metal core				
<b>Type 2423 Valve · Balanced by a diaphragm</b>					
Pressure rating	PN 16	PN 25	PN 16, 25 and 40		
Valve body	Cast iron EN-GJL-250	Spheroidal graphite iron EN-GJS-400-18-LT	Cast steel 1.0619	Cast stainless steel 1.4408 <sup>6)</sup>	-
Valve seat	Red brass <sup>3)4)</sup>				
Plug (standard version)	Red brass <sup>3)5)</sup> · With EPDM soft seal, max. 150 °C or with PTFE soft seal, max. 150 °C				
Pressure balancing	Balancing cases made of sheet steel DD11 · EPDM balancing diaphragm, max. 150 °C or FKM, version with two balancing diaphragms				
<b>Type 2427 and Type 2429 Actuators</b>					
Diaphragm cases	1.0332			1.4301	
Diaphragm	EPDM with fabric reinforcement · Special version for mineral oils: FKM				
Guide bushing	DU bushing			PTFE	
Seals	EPDM/PTFE <sup>2)</sup>				

<sup>1)</sup> DN 15, 25, 40 and 50 only

<sup>2)</sup> Special version for mineral oils: FKM

<sup>3)</sup> Special version 1.4409

<sup>4)</sup> DN 65 to 100: 1.4006

<sup>5)</sup> DN 65 to 80: 1.4104, DN 100: 1.4006, with metal seal

<sup>6)</sup> DN 125 to 250 only

## Design and principle of operation

**Table 3-4:** Dimensions in mm and weights · Type 2423 Valve **balanced by a bellows**

Nominal size	DN	15	20	25	32	40	50	65	80	100	125	150	200	250	
Overall length L		130	150	160	180	200	230	290	310	350	400	480	600	730	
Height H1		225						300		355	460	590	730		
Height H2 <sup>1)</sup>	Forged steel	113	-	130	-	170	176	-							
	Other materials	115			150			175	180	200	250	280	400		
Set point ranges <sup>3)</sup>															
0.1 to 0.6 bar	Height H <sup>1)5)</sup>	675						770		825	-				
	Actuator	ØD = 225 mm, A = 160 cm <sup>2</sup>						ØD = 285 mm, A = 320 cm <sup>2</sup>		-					
	Weight <sup>2)</sup> , approx. kg	20.5	21	22	28.5	29	31.5	56	61	71	-				
0.2 to 1 bar	Height H <sup>1)5)</sup>	675						770		825	1130	1160	1240		
	Actuator	ØD = 225 mm, A = 160 cm <sup>2</sup> <sup>4)</sup>									ØD = 285 mm, A = 320 cm <sup>2</sup>				
	Weight <sup>2)</sup> , approx. kg	20.5	21	22	28.5	29	31.5	45	50	63	130	180	420	480	
0.5 to 1.5 bar	Height H <sup>1)5)</sup>	705						780		835	1130	1160	1240		
	Actuator	ØD = 225 mm, A = 160 cm <sup>2</sup> <sup>4)</sup>									ØD = 285 mm, A = 320 cm <sup>2</sup>				
	Weight <sup>2)</sup> , approx. kg	20.5	21	22	28.5	29	31.5	45	50	63	135	185	425	485	
1 to 2.5 bar	Height H <sup>1)5)</sup>	705						780		835	1130	1160	1240		
	Actuator	ØD = 225 mm, A = 160 cm <sup>2</sup>									ØD = 285 mm, A = 320 cm <sup>2</sup>				
	Weight <sup>2)</sup> , approx. kg	20.5	21	22	28.5	29	31.5	45	50	63	135	185	425	485	
2 to 5 bar	Height H <sup>1)5)</sup>	615						690		745	-				
	Actuator	ØD = 225 mm, A = 160 cm <sup>2</sup>									-				
	Weight <sup>2)</sup> , approx. kg	20.5	21	22	28.5	29	31.5	45	50	63	-				

<sup>1)</sup> Type 42-39: add 50 mm to total height H.

<sup>2)</sup> The weight applies to the version with the material specifications EN-GJL-250/PN 16 (GG-25). Add +10 % for spheroidal graphite iron EN-GJS-400-18-LT/PN 25, cast steel 1.0619/PN 40 and 1.4404/1.4408.

<sup>3)</sup>  $\Delta p = 4.5$  to 10 bar on request

<sup>4)</sup> Optionally with 320 cm<sup>2</sup> actuator (DN 65 to 100). For regulators with double adapter Do2 (► T 3019) for DN 65 to 100, actuator 320 cm<sup>2</sup> recommended.

<sup>5)</sup> Minimum clearance required to remove the actuator: +100 mm

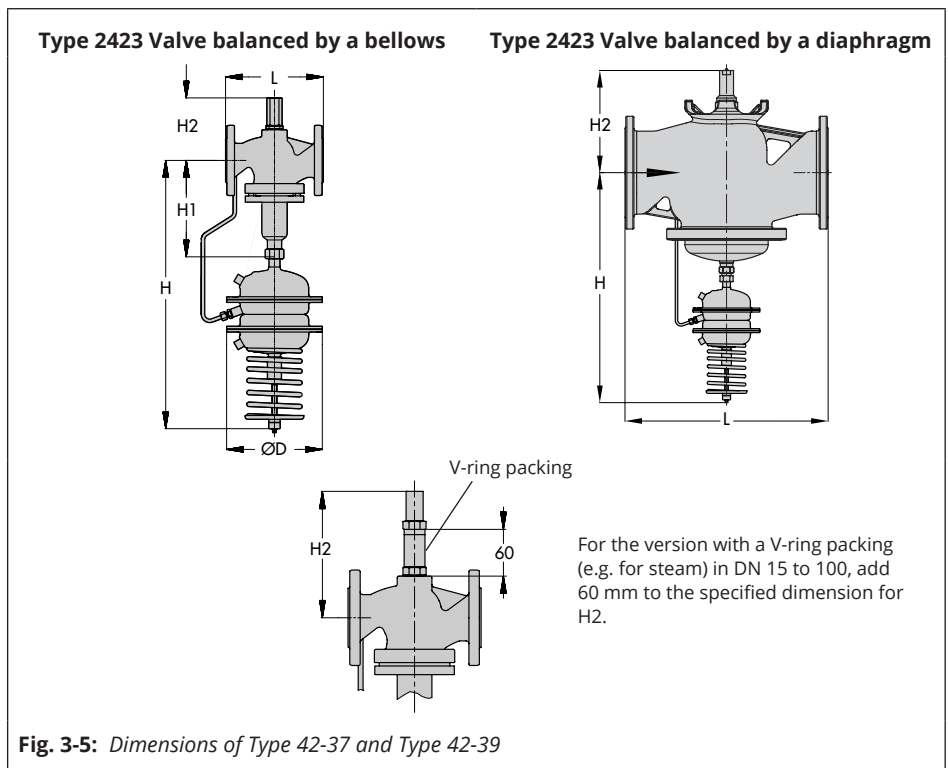
**Table 3-5: Dimensions in mm and weights · Type 2423 Valve balanced by a diaphragm**

Nominal size	DN	65	80	100	125	150	200	250
Overall length L		290	310	350	400	480	600	730
Height H <sup>2)</sup>		660		685	910	935	1020	
Height H <sub>2</sub>		195		220	295	325	345	375
<b>Weight for PN 16<sup>1)</sup> in kg (approx.)</b>								
Type 2423 Valve		34	39	49	65	85	248	268
Type 2427 Actuator		16			27		35	

1) PN 25/40: +10 %

2) Minimum clearance required to remove the actuator: +100 mm

### Dimensional drawings



**Fig. 3-5: Dimensions of Type 42-37 and Type 42-39**



### 4 Shipment and on-site transport

The work described in this chapter is to be performed only by personnel appropriately qualified to carry out such tasks.

#### 4.1 Accepting the delivered goods

After receiving the shipment, proceed as follows:

1. Check the scope of delivery. Check that the specifications on the valve and actuator nameplate match the specifications in the delivery note. See the 'Markings on the device' chapter for nameplate details.
2. Check the shipment for transportation damage. Report any damage to SAMSON and the forwarding agent (refer to delivery note).
3. Determine the weight and dimensions of the units to be lifted and transported in order to select the appropriate lifting equipment and lifting accessories. Refer to the transport documents and the 'Design and principle of operation' chapter.

#### 4.2 Removing the packaging from the regulator

The components (valve, actuator and, if applicable, control line) of the regulator are delivered separately. A tested regulator is delivered as an assembled unit.

Proceed as follows to lift and install the valve:

- Do not open or remove the packaging until immediately before lifting to install the regulator into the pipeline.
- Leave the regulator components in its transport container or on the pallet to transport it on site.
- Do not remove the protective caps from the inlet and outlet until immediately before installing the valve into the pipeline. They prevent foreign particles from entering the valve.
- Dispose and recycle the packaging in accordance with the local regulations.

## 4.3 Transporting and lifting the regulator

### DANGER

#### **Danger due to suspended loads falling.**

- Stay clear of suspended or moving loads.
- Close off and secure the transport paths.

### WARNING

#### **Risk of injury due to incorrect lifting without the use of lifting equipment.**

Lifting the regulator without the use of lifting equipment may lead to injuries (back injuries in particular) depending on its weight.

- Observe the occupational health and safety regulations valid in the country of use.
- Observe the guideline weight for manual handling: 15 to max. 55 kg taking into account age, gender and physical fitness.
- When the actuator is filled with medium, take the weight of the medium also into account.
- Refer to the 'Design and principle of operation' chapter for the weights of the regulator and actuator.

### WARNING

#### **Risk of personal injury due to the regulator tipping.**

- Observe the regulator's center of gravity.
- Secure the regulator against tipping over or turning.

### WARNING

#### **Risk of lifting equipment tipping over and risk of damage to lifting accessories due to exceeding the rated lifting capacity.**

- Only use approved lifting equipment and accessories whose minimum lifting capacity is higher than the weight of the valve (including actuator and packaging, if applicable).
- Refer to the 'Design and principle of operation' chapter for the weights.

### Tip

Our after-sales service can provide more detailed transport and lifting instructions on request.

### 4.3.1 Transporting the regulator

The regulator can be transported using lifting equipment (e.g. crane or forklift).

- Leave the regulator in its transport container or on the pallet to transport it.



- Observe the transport instructions.

### Transport instructions

- Protect the regulator against external influences (e.g. impact).
- Protect the regulator against moisture and dirt.
- Do not damage the corrosion protection (paint, surface coatings). Repair any damage immediately.
- Protect the piping and any mounted valve accessories against damage.
- The permissible ambient temperature of standard regulators is  $-20$  to  $+80$  °C.

### 4.3.2 Lifting the regulator

To install a large regulator into the pipeline, use lifting equipment (e.g. crane or forklift) to lift it.

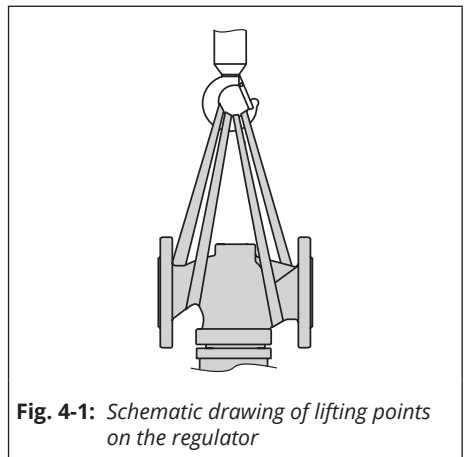
#### Lifting instructions

- Use a hook with safety latch to secure the slings from slipping off the hook during lifting and transporting (see Fig. 4-1).
- Secure slings against slipping.
- Make sure the slings can be removed from the device once it has been installed into the pipeline.
- Prevent the regulator from tilting or tipping.
- Do not leave loads suspended when interrupting work for longer periods of time.

- Make sure that the axis of the pipeline is always horizontal during lifting and the axis of the plug stem is always vertical.

#### Lifting

1. Attach one sling to the body flange and one sling to the rigging equipment (e.g. hook) of the crane or forklift (see Fig. 4-1).
2. Carefully lift the regulator. Check whether the lifting equipment and accessories can bear the weight.
3. Move the regulator at an even pace to the site of installation.
4. Install the regulator into the pipeline (see the 'Installation' chapter).
5. After installation in the pipeline, check whether the regulator flanges are bolted tight.
6. Remove slings.



**Fig. 4-1:** Schematic drawing of lifting points on the regulator

### 4.4 Storing the regulator

---

#### NOTICE

#### **Risk of regulator damage due to improper storage.**

- Observe the storage instructions.
  - Avoid longer storage periods.
  - Contact SAMSON in case of different storage conditions or longer storage times.
- 

#### Note

SAMSON recommends to regularly check the regulator and the prevailing storage conditions during long storage periods.

---

#### Storage instructions

- Protect the regulator against external influences (e.g. impact).
- Secure the regulator in the stored position against slipping or tipping over.
- Do not damage the corrosion protection (paint, surface coatings). Repair any damage immediately.
- Protect the regulator against moisture and dirt. Store it at a relative humidity of less than 75 %. In damp spaces, prevent condensation. If necessary, use a drying agent or heating.
- Make sure that the ambient air is free of acids or other corrosive media.

- The permissible storage temperature of standard regulators is -20 to +65 °C.
- Do not place any objects on the regulator.

#### Special storage instructions for elastomers

Elastomer, e.g. operating diaphragm

- To keep elastomers in shape and to prevent cracking, do not bend them or hang them up.
  - Store elastomers away from lubricants, chemicals, solutions and fuels.
    - SAMSON recommends a storage temperature of 15 °C for elastomers.
- 

#### Tip

*Our after-sales service can provide more detailed storage instructions on request.*

---

## 5 Installation

The work described in this chapter is to be performed only by personnel appropriately qualified to carry out such tasks.

### 5.1 Installation conditions

#### Work position

The work position for the regulator is the front view onto all operating controls on the regulator (including any additional fittings) seen from the position of operating personnel.

Plant operators must ensure that, after installation of the device, the operating personnel can perform all necessary work safely and easily access the device from the work position.

#### Pipeline routing

The inlet and outlet lengths vary depending on several variables and process conditions and are intended as recommendations. Contact SAMSON if the lengths are significantly shorter than the recommended lengths.

To ensure that the regulator functions properly, proceed as follows:

- Observe the inlet and outlet lengths (see Table 5-1). Contact SAMSON if the regulator conditions or state of the process medium are different from those specified.
- Install the regulator free of stress and with the least amount of vibrations as possible. Read sections

“Mounting position” and “Support or suspension” in this chapter.

- For media with a tendency to condensate, install the pipeline with a slight downward slope on both sides so that the condensate can drain properly. If the pipeline upstream and downstream of the regulator run vertically upwards, an automatic drainage is required.
- Install the regulator allowing sufficient space to remove the actuator and valve or to perform service work on them.

#### Mounting position

To ensure that the regulator functions properly, proceed as follows:

- Standard mounting position: install the actuator housing suspended downward in horizontal pipelines (see Fig. 5-1).
- Make sure the direction of flow matches the direction indicated by the arrow on the body.
- Contact SAMSON if the mounting position is not as specified above.

---

#### **NOTICE**

##### ***Damage due to freezing.***

*Protect the regulator from icing up when controlling media that can freeze. Unless the regulator is installed in locations where no frost occurs, remove the regulator from the pipeline when the plant is shut down.*

---

## Installation

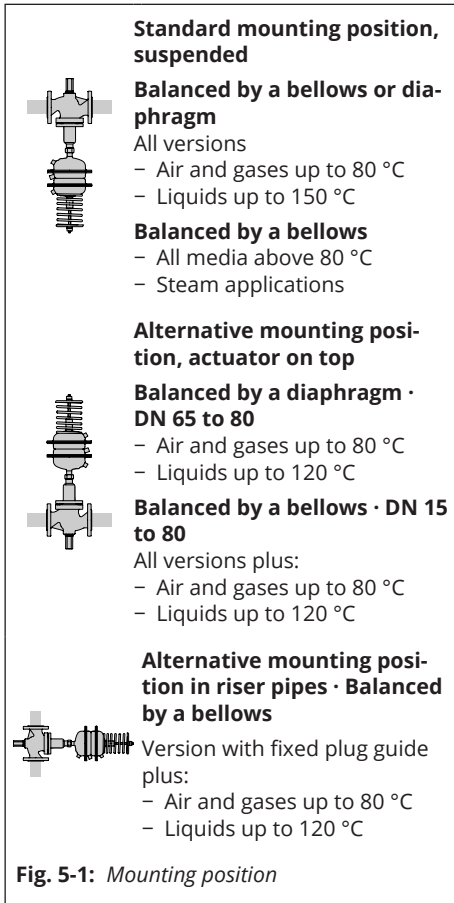


Fig. 5-1: Mounting position

## Support or suspension

### **i** Note

The plant engineering company is responsible for selecting and implementing a suitable support or suspension of the installed regulator and the pipeline.

Depending on the regulator version and mounting position, the valve, actuator and pipeline must be supported or suspended.

### **!** NOTICE

**Risk of regulator damage due to incorrect support.**

- Do not attach supports to the valve, to moving parts on the actuator or to the control lines.
- Contact SAMSON if the mounting position differs from the standard mounting position.

## Control line

### – Control line (Type 42-37)

Attach the supplied low-pressure control line to the regulator (see the 'Design and principle of operation' chapter).

Route the high-pressure control line with 8 mm (standard), 10 mm or 12 mm pipe diameter at the site of installation from the bottom diaphragm chamber to the high-pressure line (flow pipe) of the plant.

### – Control line (Type 42-39)

Mount the control lines (supplied with the regulator) to the regulator (see the 'Design and principle of operation' chapter).

When used as a differential pressure and flow regulator, additionally route a control line on site from diaphragm chamber C to the low-pressure line (return pipe) of the plant. When used as

a pressure and flow regulator, the connection of the diaphragm chamber C remains open.

– **Control lines to be installed on site (Type 42-37 and Type 42-39)**

Route the control line on site preferably using a 8x1 mm (stainless) steel pipe.

The control line for tapping pressure from the pipeline (for Type 42-37) must be installed upstream of the consumer. The pressure tapping point must at least three times the nominal size (DN) away from any pipe fittings (e.g. restrictions, bends or branches), that may cause turbulence in the flow (see Fig. 5-2). How the lines are routed generally depends on the installation site.

The same conditions apply to routing the control line of Type 42-39 on site (connection downstream of the consumer).

- ➔ Preferably connect the control line to the side of the main pipe (see Fig. 5-3).
- ➔ Do not change the pipe diameter of the main pipeline with an eccentric reducer.

**Control line kit**

Ready-made control line kits for direct pressure tapping at the valve body are optionally available from SAMSON. They are optimized to handle the pressure and flow conditions in the valve and are available as accessories from SAMSON (▶ T 3095).

**Compensation chamber**

A compensation chamber (18) is required for liquids above 150 °C as well as for steam. Install the compensation chamber at the highest point of the pipeline. The mounting position of the compensation chamber is indicated by an adhesive label on the chamber itself as well as by an arrow and the word "top" stamped on the top of the chamber.

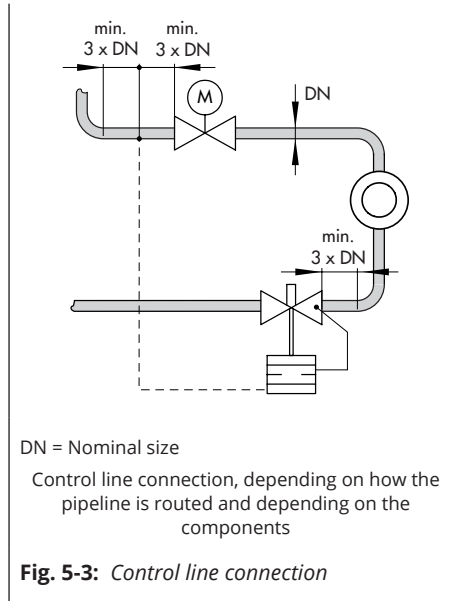
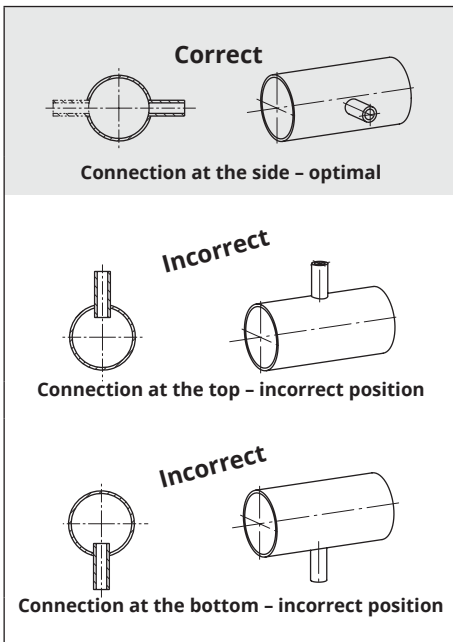
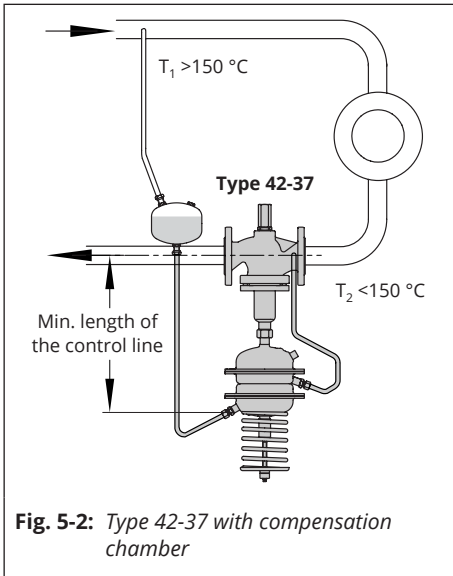
Before start-up, fill the compensation chamber with the process medium. This prevents hot medium coming into direct contact with the diaphragm (see Fig. 5-2).

Installation near the pressure tapping point in the flow pipe or at the same height as the valve with the control line reaching at least from the mid-axis of the pipeline (valve) to the actuator. This allows the hot medium to cool down sufficiently (see Fig. 5-2).

Depending on the conditions, install the compensation chamber in the the hot control line.

- ➔ This mounting position must be adhered to; otherwise the safe functioning of the regulator cannot be guaranteed.

## Installation



### Needle valve

If the regulator tends to hunt, SAMSON recommends installing a needle valve in the control line in addition to the standard SAMSON screw joint with restriction.

#### Tip

Needle valves, compensation chambers and compression-type screw fittings can be supplied as required. These accessories are listed in ► T 3095.

## 5.2 Preparation for installation

The valve and actuator of regulators that have not yet been assembled or have been tested beforehand can be assembled before or after the valve has been installed in the pipeline. SAMSON recommends first installing the valve without the actuator into the pipeline.

Before installation, make sure that the following conditions are met:

- The valve is clean.
- The valve, actuator and all piping are not damaged.
- Install a strainer upstream of the regulator.
- The valve data on the nameplate (type designation, nominal size, material, pressure rating and temperature range) match the plant conditions (nominal size and pressure rating of the pipeline, medium temperature etc.). See the 'Markings on the device' chapter for nameplate details.
- The requested or required additional fittings have been installed or prepared as necessary before installing the valve (see the 'Design and principle of operation' chapter).

Proceed as follows:

- Flush the pipeline **before** installing the regulator.  
The plant operator is responsible for cleaning the pipelines in the plant.
- For steam applications, dry the pipelines. Moisture will damage the inside of the regulator.
- Check any mounted pressure gauges to make sure they function properly.
- Lay out the necessary material and tools to have them ready during installation work.

### 5.3 Installation

Tested SAMSON regulators are delivered as an assembled unit. In all other cases, the separate components (valve, actuator, control line and accessories) of the regulator are delivered separately. Upon delivery, the separate components must be assembled together. The activities listed below are necessary for installation and before start-up of the regulator.

#### **⚠ DANGER**

##### ***Danger due to suspended loads falling.***

- Stay clear of suspended or moving loads.
- Close off and secure the transport paths.

#### **⚠ WARNING**

##### ***Risk of injury due to incorrect lifting without the use of lifting equipment.***

*Lifting the regulator without the use of lifting equipment may lead to injuries (back injuries in particular) depending on the weight of the regulator and/or actuator.*

- Observe the guideline weight for manual handling: 15 to max. 55 kg per person taking into account age, gender and physical fitness.
- When the actuator is filled with medium, take the weight of the medium also into account.
- Refer to the 'Design and principle of operation' chapter for the weights of the regulator and actuator.

- Observe the occupational health and safety regulations valid in the country of use.

#### **⚠ WARNING**

##### ***Risk of lifting equipment tipping over and risk of damage to lifting accessories due to exceeding the rated lifting capacity.***

- Only use approved lifting equipment and accessories whose minimum lifting capacity is higher than the weight of the valve (including actuator and packaging, if applicable).
- Refer to the 'Design and principle of operation' chapter for the weights.

#### **⚠ WARNING**

##### ***Risk of personal injury due to the regulator tipping.***

- Observe the regulator's center of gravity.
- Secure the regulator against tipping over or turning.

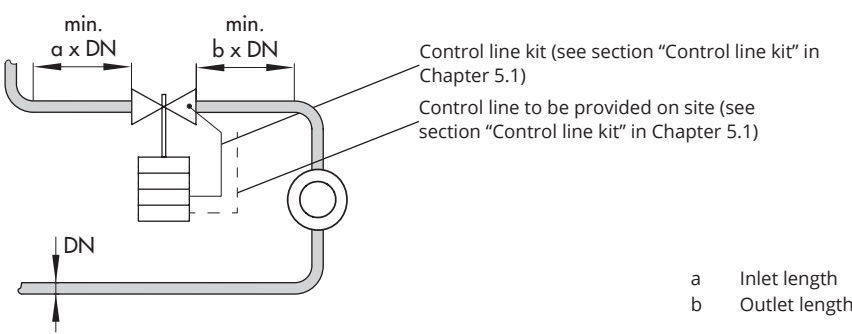
#### **ⓘ NOTICE**

##### ***Risk of regulator damage due to the use of unsuitable tools.***

- Only use tools approved by SAMSON (see the 'Tools' chapter in the Appendix).

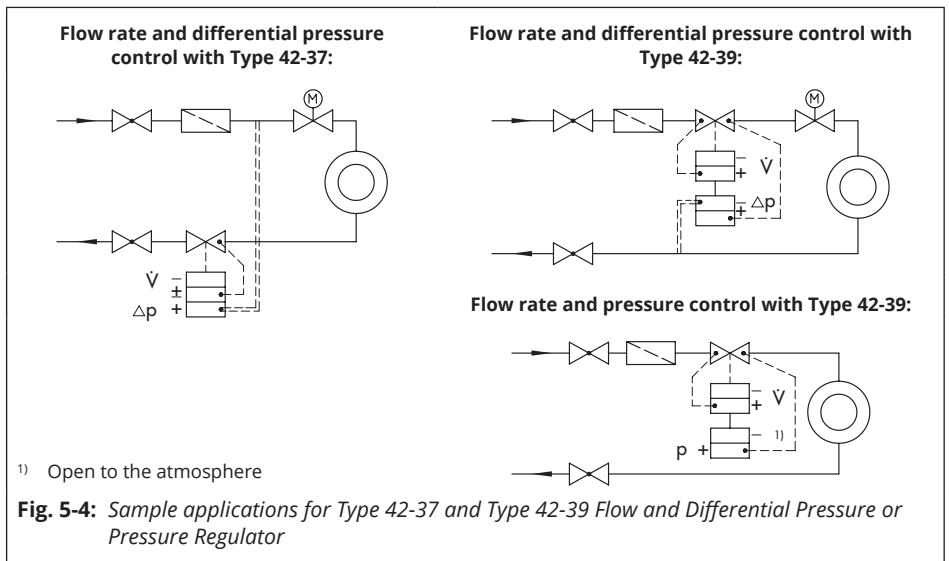


**Table 5-1: Inlet and outlet lengths**



State of process medium	Valve conditions	Inlet length a	Outlet length b
Gas	$Ma \leq 0.3$	2	4
Vapors <sup>1)</sup>	$Ma \leq 0.3$	2	4
Liquid	Free of cavitation/ $w < 3 \text{ m/s}$	2	4
	Cavitation producing noise/ $w \leq 3 \text{ m/s}$	2	4

<sup>1)</sup> No wet steam



**Fig. 5-4: Sample applications for Type 42-37 and Type 42-39 Flow and Differential Pressure or Pressure Regulator**

---

### **NOTICE**

#### **Risk of regulator damage due to the use of unsuitable lubricants.**

→ Only use lubricants approved by SAMSON (see the 'Lubricants' chapter in the Appendix).

---

### **NOTICE**

#### **Risk of regulator damage due to over- or under-torquing.**

Observe the specified torques when tightening regulator components. Excessive tightening torques lead to parts wearing out more quickly. Parts that are too loose may cause leakage.

→ Observe the specified tightening torques (see the 'Tightening torques' chapter in the Appendix).

---

### 5.3.1 Installing the regulator

---

#### **i Note**

Before installing the regulator, tighten the blanking plug(s) at the side of the valve body using a suitable box wrench (see 'Tightening torques' in the Appendix).

---

The regulator can be installed into the downstream pressure pipe (return pipe) or the upstream pressure pipe (flow pipe) of the plant. See installation examples in Fig. 5-4.

1. Close the shut-off valves (1, 9) upstream and downstream of the regulator while the regulator is being installed.
  2. Remove the protective caps from the valve ports before installing the valve.
  3. Lift the regulator using suitable lifting equipment to the site of installation. Observe the flow direction through the valve. The arrow on the valve indicates the direction of flow.
  4. Make sure that the correct flange gaskets are used.
  5. Bolt the pipe to the valve free of stress.
- **Additional activities required for individual components**
6. Mount the actuator.
    - Fasten the actuator on the valve by tightening the coupling nut (11). Observe the alignment of the control line connection. Observe the specified tightening torques (see the 'Tightening torques' chapter in the Appendix).
  7. Mount the control line.
    - Mount the control line onto the valve and actuator. Observe the specified tightening torques (see the 'Tightening torques' chapter in the Appendix).
    - For **steam** or **liquids above 150 °C**: Install the compensation chamber and fill it with the process medium.

Observe the specified tightening torques (see the 'Tightening torques' chapter in the Appendix).

8. Slowly open the shut-off valves in the pipeline after the valve has been installed.

## 5.4 Testing the regulator

### **⚠ DANGER**

**Risk of bursting due to incorrect opening of pressurized equipment or components.**

Regulators and pipelines are pressure equipment that may burst when handled incorrectly. Flying projectile fragments or the release of process medium under pressure can cause serious injury or even death.

Before working on the regulator:

- ➔ Depressurize all plant sections concerned and the regulator.
- ➔ Disconnect the control line.
- ➔ Drain the process medium from the plant sections affected as well as from the valve.

### **⚠ DANGER**

**Risk of personal injury due to process medium escaping.**

- ➔ Do not unscrew the control line while the valve is pressurized.
- ➔ Do not start up the regulator until all parts have been mounted.

### **⚠ WARNING**

**Risk of hearing loss or deafness due to loud noise.**

Noise emission (e.g. cavitation) may occur during operation caused by the process medium and the operating conditions.

- ➔ Wear hearing protection when working near the valve. Follow the instructions given by the plant operator.

### **⚠ WARNING**

**Risk of burn injuries due to hot or very cold components and pipelines.**

Depending on the process medium, valve components and pipelines may get very hot or cold and cause burn injuries.

- ➔ Wear protective clothing and safety gloves.

SAMSON regulators are delivered ready for use. To test the regulator functioning before start-up or putting back the regulator into operation, perform the following tests:

### 5.4.1 Leak test

The plant operator is responsible for performing the leak test and selecting the test method. The leak test must comply with the requirements of the national and international standards that apply at the site of installation.



### Tip

SAMSON's After-sales Service can support you to plan and perform a leak test for your plant.

- All required control lines are connected to the actuator and are not shut off.
- 1. Install the regulator into the pipeline (see Chapter "Installation").
- 2. Apply the required test pressure.
- 3. Check the regulator for leakage to the atmosphere.
- 4. Depressurize the pipeline section and valve.
- 5. Rework any parts that leak and repeat the leak test.

### 5.4.2 Pressure test



### WARNING

**Risk of personal injury due to pressurized components and as a result of process medium being discharged.**

*Incorrect opening of pressure equipment or mounting parts may lead to the process medium escaping to the atmosphere.*

- *Do not unscrew the control line while the valve is pressurized.*
- *Do not start up the regulator until all parts have been mounted.*



### Note

*The plant operator is responsible for performing the pressure test. SAMSON's After-sales Service can support you to plan and perform a pressure test for your plant.*



### NOTICE

**Risk of valve damage due to a sudden pressure increase and resulting high flow velocities.**

- *Slowly open the shut-off valves.*

During the pressure test, make sure the following conditions are met:

#### Pressure test with mounted diaphragm actuator

- All required control lines are connected to the actuator and are not shut off.
- Do not allow the pressure to exceed 1.5 times the pressure rating of the valve body.
- Do not apply a pressure higher than the maximum specified pressure rating or maximum operating pressure to the actuator (see section 'Technical data' in the 'Design and principle of operation' chapter).
- Make sure that the pressure rises simultaneously upstream and downstream of the regulator to avoid damaging the balancing bellows or the balancing diaphragm.

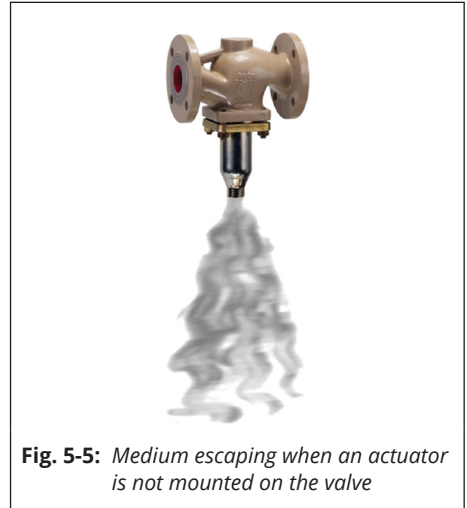
If the **test pressure** of the valve is **higher** than the specified maximum permissible operating pressure of the diaphragm actuator, the pressure test is always performed **without** a mounted diaphragm actuator.

### Pressure test without mounted diaphragm actuator

- Depressurize the plant and remove the control line. Close any control line connection in the plant by closing the installed shut-off valve or inserting a blanking plug.
- Seal the body connections with blanking plugs.

If the valve is not sealed off, the test medium escapes at the connection where the actuator is connected to the valve. It is not possible to perform a pressure test on the valve in this case (see Fig. 5-5).

- Seal off the valve using a coupling nut (0250-1037) with seal (0340-1962).



**Fig. 5-5:** *Medium escaping when an actuator is not mounted on the valve*

## 5.4.3 Filling the plant

Open the shut-off valves slowly over a time period of several minutes preferably starting from the upstream pressure side to fill the plant (all consumers and control lines are open).

- Make sure that the pressure rises simultaneously upstream and downstream of the regulator to avoid damaging the balancing bellows or the balancing diaphragm.

### ⚠ NOTICE

#### **Risk of regulator damage due to steam hammering.**

*Steam hammering is possible when the process medium is a liquid with a boiling point at atmospheric pressure.*

## Installation

→ *Open the shut-off valves slowly preferably starting from the downstream side to fill the plant over a time period of several minutes.*

---

### 5.4.4 Cleaning the pipeline

SAMSON recommends additionally flushing the pipeline with installed regulator over a time period of several minutes before start-up.

- All required control lines are connected and not shut off.
- Before flushing the plant with the process medium, read the section 'Starting up the plant' in the 'Start-up' chapter.
- Higher set points for the differential pressure and flow rate are adjusted at the regulator. All consumers are open to guarantee a high flow rate.
- Observe the mesh size of the upstream strainer for the maximum particle size. Use strainers to suit the process medium.
- Check the strainer for dirt each time the pipeline is flushed and clean it, if necessary.

If the regulator malfunctions due to clogging after flushing the pipeline, proceed as described in the 'Troubleshooting' chapter.

## 5.5 Insulation

To insulate cold systems, SAMSON recommends first filling the plant and carefully rinsing it. The regulator must not yet be insulated at this stage.

1. Start up the plant and adjust the set point (see the 'Start-up' chapter).
2. Shut down the plant again and let it heat up until the condensation water has dried off.
3. Insulate the regulator and pipes conveying the process medium using insulation material with a water vapor barrier. If a control line is to be routed through the insulation, special care must be taken with the sealing since slight changes in shape may occur. The insulation thickness depends on the medium temperature and the ambient conditions. A typical value is 50 mm. If the valve has an external spring, it must be protected by a sleeve to allow it to move. The spring-loaded actuator stem must not touch the insulation.

---

### **!** NOTICE

***Risk of regulator damage due to incorrect insulation.***

- *The actuator must also be insulated for medium temperatures below 0 °C.*
  - *Only insulate the regulator up to the actuator for medium temperatures above 220 °C.*
-

## 6 Start-up

The work described in this chapter is to be performed only by personnel appropriately qualified to carry out such tasks.

### **⚠ WARNING**

#### **Risk of burn injuries due to hot or cold components and pipeline.**

*Regulator components and the pipeline may become very hot or cold. Risk of burn injuries.*

- *Allow components and pipelines to cool down or warm up to the ambient temperature.*
- *Wear protective clothing and safety gloves.*

### **⚠ WARNING**

#### **Risk of personal injury due to pressurized components and as a result of process medium being discharged.**

- *Do not unscrew the control line while the valve is pressurized.*
- *Do not start up the regulator until all parts have been mounted.*

### **⚠ WARNING**

#### **Risk of hearing loss or deafness due to loud noise.**

*Noise emission (e.g. cavitation) may occur during operation caused by the process medium and the operating conditions.*

- *Wear hearing protection when working near the valve. Follow the instructions given by the plant operator.*

### **⚠ DANGER**

#### **Risk of personal injury due to process medium escaping.**

- *Do not start up the regulator until all parts have been mounted.*

Before start-up or putting the device back into service, make sure the following conditions are met:

- The regulator is properly installed in the pipeline (see the 'Installation' chapter).
- The leak and function tests have been completed successfully (see section 'Testing the regulator' in the 'Installation' chapter).
- The prevailing conditions in the plant section concerned meet the regulator sizing requirements (see section 'Intended use' in the 'Safety instructions and measures' chapter).

### 6.1 Start-up and putting the device back into operation

1. Depending on the field of application, allow the regulator to cool down or warm up to reach ambient temperature before start up.
2. Slowly open the shut-off valves in the pipeline. Slowly opening these valves prevents a sudden surge in pressure and high flow velocities which may damage the valve.
3. Check the regulator to ensure it functions properly (see section 'Adjusting the flow rate' and 'Adjusting the differential pressure set point' or 'Adjusting the pressure set point' in the 'Operation' chapter).

Before starting up the plant, make sure the following conditions are met:

- The control line is open (needle valve) and correctly connected.

### 6.2 Starting up the plant

---

#### **⚠ WARNING**

#### ***Risk of personal injury due to process medium escaping.***

*Depending on the conditions in the plant in operation, it may be necessary to install compensation chambers to protect the regulator.*

→ *Proceed as described in Chapter 6.2.1 and Chapter 6.2.2 for liquids or steam above 150 °C before starting up the plant.*

---

1. The plant (e.g. consumer valve) must be open while the plant is being filled.
2. The control lines are correctly connected.
3. **For media that do not reach their boiling point:**  
Open the shut-off valves **slowly** over a time period of several minutes starting from the upstream pressure side. Fill the plant with the medium.  
**For media that reach their boiling point:**  
Open the shut-off valves **slowly** starting from the downstream side to avoid steam hammering.
4. Make sure that the pressure rises simultaneously upstream and downstream of the regulator to avoid damaging the balancing bellows.



**i Note**

*On filling the plant, make sure the restriction (1.1) is open by turning the set point adjuster for the flow rate (1.4) counter-clockwise (↺) as far as it will go.*

### 6.2.1 Control applications with liquids

- ➔ Vent the bellows housing of valves balanced by a bellows (DN 125 and larger) at the stopper (8) located at the side.
- ➔ For liquids with temperatures above 150 °C, first fill the compensation chamber with the process medium. Proceed as follows:
  1. Unscrew filler plug from the compensation chamber.
  2. Use the included plastic funnel or a jug to pour in the process medium until it starts to overflow.
  3. Screw the filler plug back in and tighten it.

### 6.2.2 Control applications with steam

- ➔ Type 42-39 only
- ➔ Warm up the plant very slowly. During this procedure, drain off any condensate and vent the plant.
- ➔ First fill the compensation chamber with water. Proceed as follows:
  1. Unscrew filler plug from the compensation chamber.
  2. Use the included plastic funnel or a jug to pour in water until it starts to overflow.
  3. Screw the filler plug back in and tighten it.
    - All pipes conveying the process medium must be completely drained and dry.
    - Air and condensate must be allowed to escape from the plant.
    - Allow time for the pipes and valves to heat up.



## 7 Operation

Immediately after completing start-up or placing the regulator back into service (see the 'Start-up' chapter), the regulator is ready for use.

### **⚠ WARNING**

#### **Risk of burn injuries due to hot or cold components and pipeline.**

*Regulator components and the pipeline may become very hot or cold. Risk of burn injuries.*

- Allow components and pipelines to cool down or warm up to the ambient temperature.
- Wear protective clothing and safety gloves.

### **⚠ WARNING**

#### **Risk of personal injury due to pressurized components and as a result of process medium being discharged.**

- Do not unscrew the control line while the valve is pressurized.
- Do not start up the regulator until all parts have been mounted.

### **⚠ WARNING**

#### **Risk of hearing loss or deafness due to loud noise.**

*Noise emission (e.g. cavitation) may occur during operation caused by the process medium and the operating conditions.*

- Wear hearing protection when working near the valve. Follow the instructions given by the plant operator.

## 7.1 Adjusting the set point

- The control and shut-off valves as well as all consumers or a bypass valve (if installed) must be open to ensure that the maximum flow rate is reached.
- Set the required flow rate by adjusting the restriction (1.4), while watching, for example the reading of a flow rate measuring unit at the heat meter (see Table 7-1).

### **i Note**

*Adjustment is always based on the closed restriction.*

- Turning it clockwise (↻) closes the restriction; the flow rate drops.
- Turning it counterclockwise (↺) opens the restriction; the flow rate rises.

To adjust the flow rate, use the adjustment diagrams for water (Fig. 7-1 to Fig. 7-8).

### **i Note**

*Observe the differential pressure across the restriction  $\Delta p_{\text{restriction}}$  of 0.2 bar or 0.5 bar. It is determined by the differential pressure springs (9) installed in the actuator (see the 'Markings on the device' chapter).*

## Operation

### 7.2 Adjusting the flow set point

- All required control lines are connected to the actuator and are not shut off.
  - To adjust the flow rate, first set the set point for pressure or differential pressure to its maximum value (this causes the differential pressure control to be deactivated. Only the flow control is still effective). To do this, tension the set point spring (16) at the set point adjuster (17 or 22) by turning it clockwise (↻).
1. Unscrew the cap (1.3).
  2. Undo lock nut (1.2) and turn the flow set point adjuster (1.4) clockwise as far as it will go.
  3. Find the flow rate set point in the diagram and determine the associated number of turns.
  4. Based on a closed restriction, turn the set point adjuster for the flow rate (1.4) counterclockwise (↺) to adjust this value. Wait until the plant has settled. If necessary, readjust.
  5. Check the flow rate at the heat meter and correct it, if necessary.
  6. Lock the restriction screw in place with the nut (1.2) and screw the cap (1.3) back on after the required flow rate is reached.
  7. Close a possibly open bypass valve again.

8. Lead-seal the setting, if necessary.

**Table 7-1: Flow rate set point ranges for water**

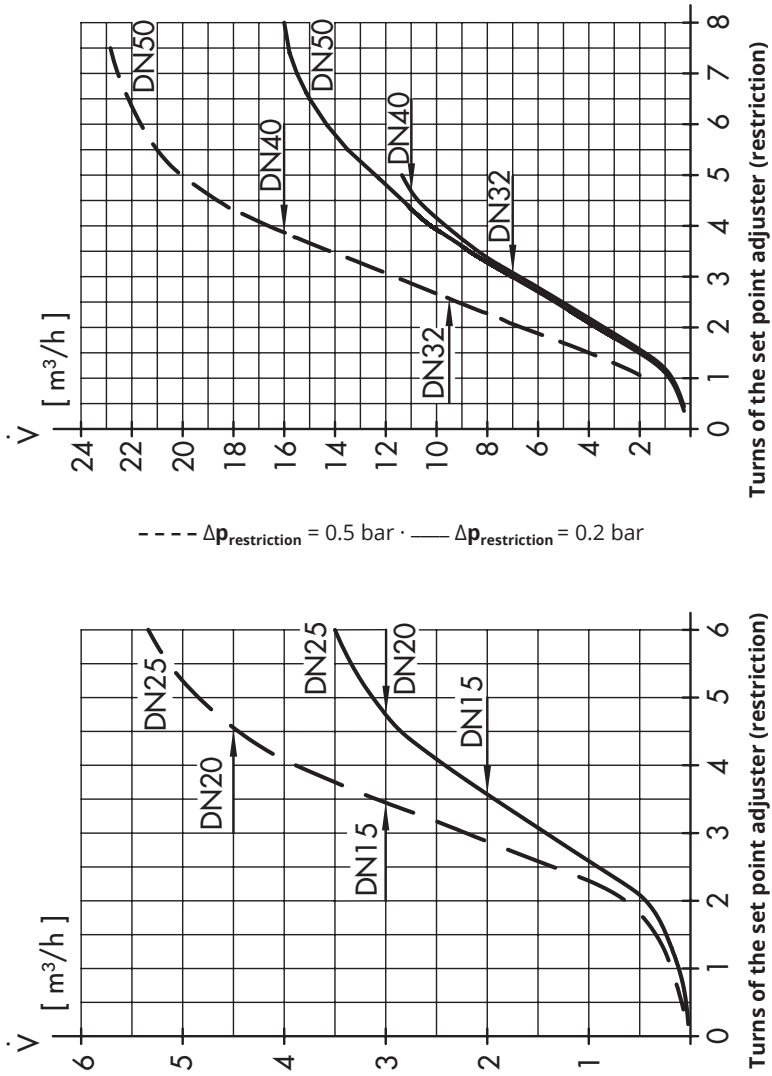
**Type 2423 · Balanced by a bellows**

Nominal size DN	15	20	25	32	40	50	65	80	100	125	150	200	250	
<b>Flow rate set point ranges for water in m<sup>3</sup>/h</b>														
Diff. pressure across restriction $\Delta p_{\text{restriction}}$	0.2 bar	0.05 to 2	0.15 to 3	0.25 to 3.5	0.4 to 7	0.6 to 11	0.9 to 16	2 to 28	3.5 to 35 <sup>1)</sup>	6.5 to 63	11 to 80	18 to 120	20 to 180	26 to 220
	0.5 bar	0.15 to 3	0.25 to 4.5	0.4 to 5.3	0.6 to 9.5	0.9 to 16	2 to 24	3.5 to 40	6.5 to 55	11 to 90	18 to 120	20 to 180	26 to 260	30 to 300
Max. permissible differential pressure $\Delta p$	25 bar						20 bar			16 bar		12 bar	10 bar	

**Type 2423 · Balanced by a diaphragm**

Nominal size DN	65	80	100	125	150	200	250	
<b>Flow rate set point ranges for water in m<sup>3</sup>/h</b>								
Diff. pressure across restriction $\Delta p_{\text{restriction}}$	0.2 bar	2 to 28	3.5 to 35 <sup>1)</sup>	6.5 to 63	11 to 120	18 to 180	20 to 320	26 to 350
	0.5 bar	3.5 to 40	6.5 to 55	11 to 90	18 to 180	20 to 260	26 to 450	30 to 520
Max. permissible differential pressure $\Delta p$	10 bar			12 bar			10 bar	

<sup>1)</sup> 7 to 35 m<sup>3</sup>/h (160 cm<sup>2</sup> actuator), 7 to 40 m<sup>3</sup>/h (320 cm<sup>2</sup> actuator)



Adjustment diagrams for water

Fig. 7-1: Adjustment diagram for Type 2423, balanced by a bellows, DN 15 to 50

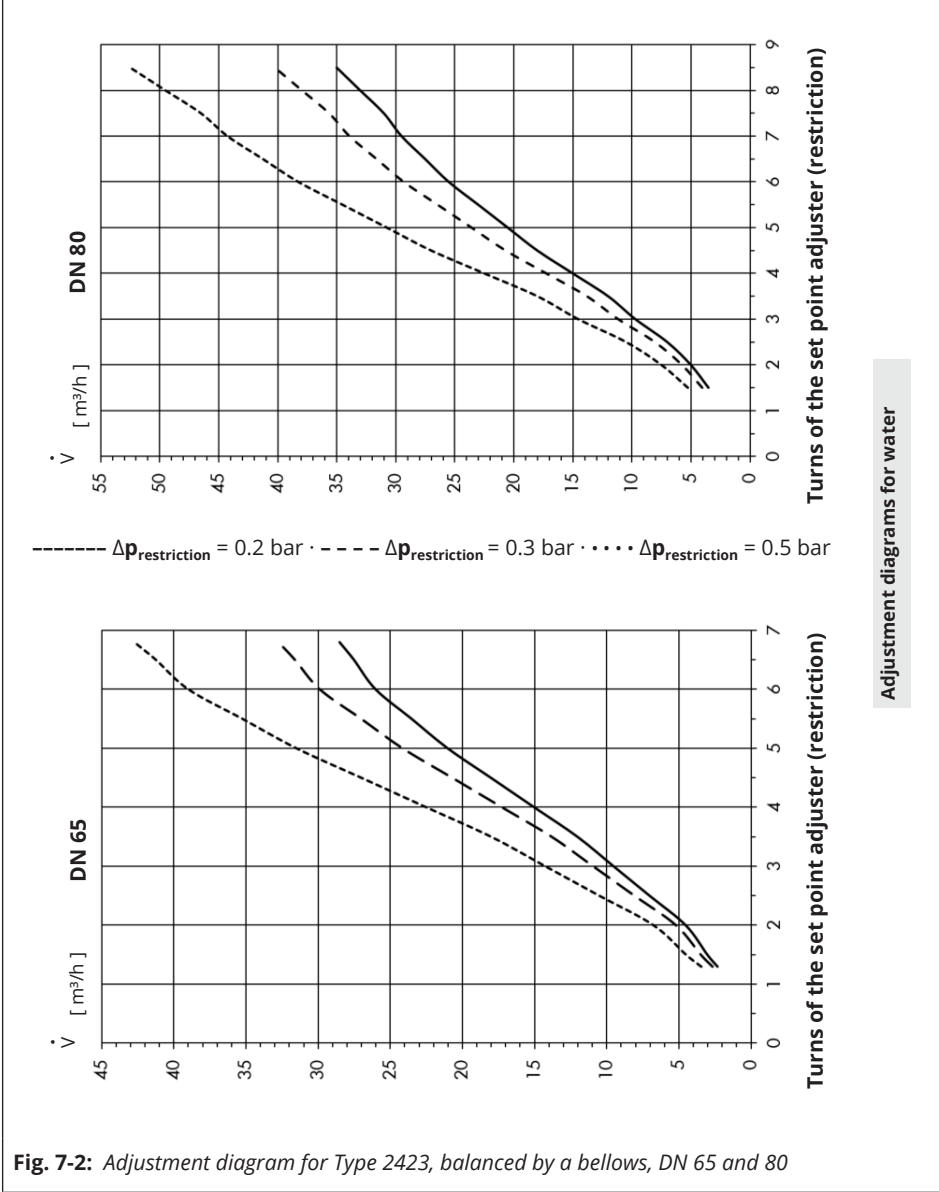


Fig. 7-2: Adjustment diagram for Type 2423, balanced by a bellows, DN 65 and 80

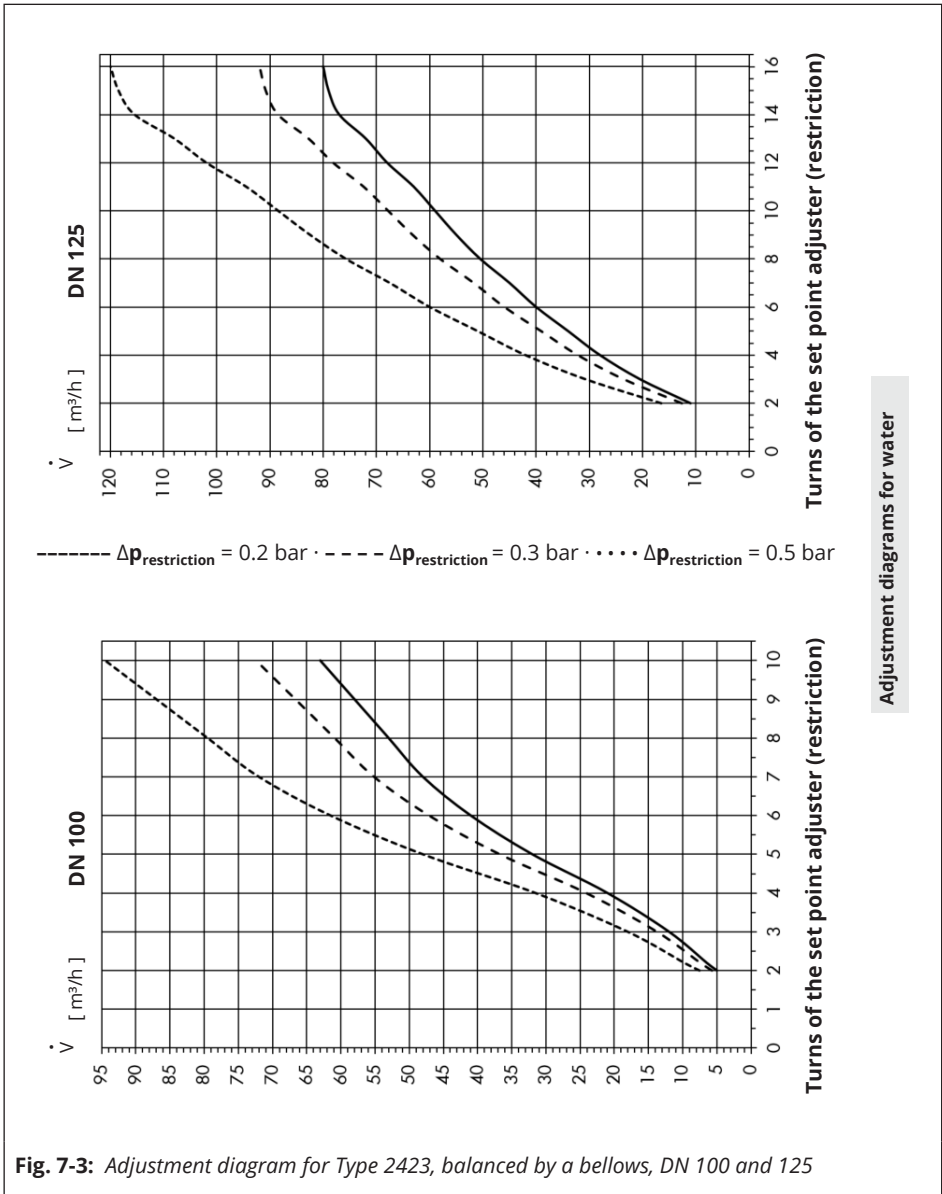


Fig. 7-3: Adjustment diagram for Type 2423, balanced by a bellows, DN 100 and 125



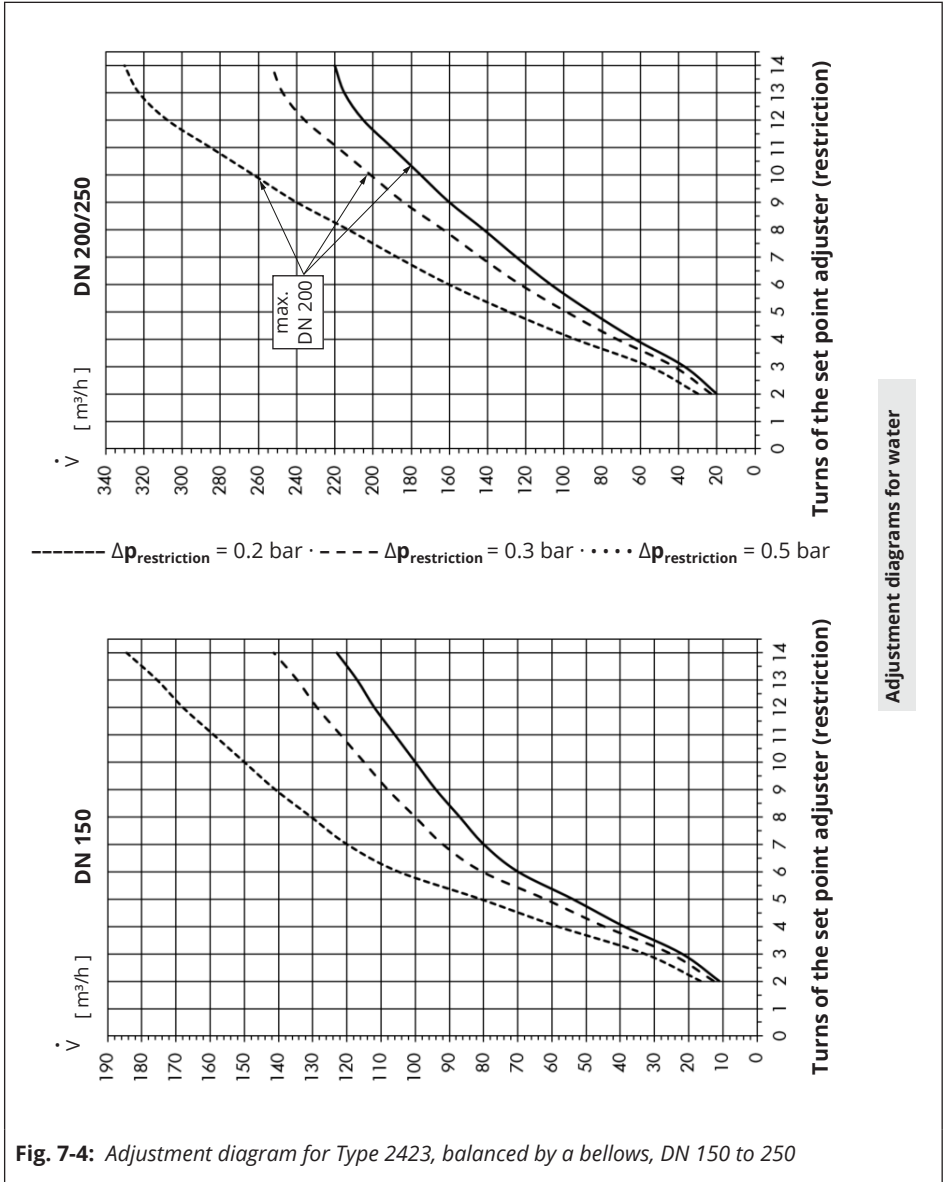


Fig. 7-4: Adjustment diagram for Type 2423, balanced by a bellows, DN 150 to 250

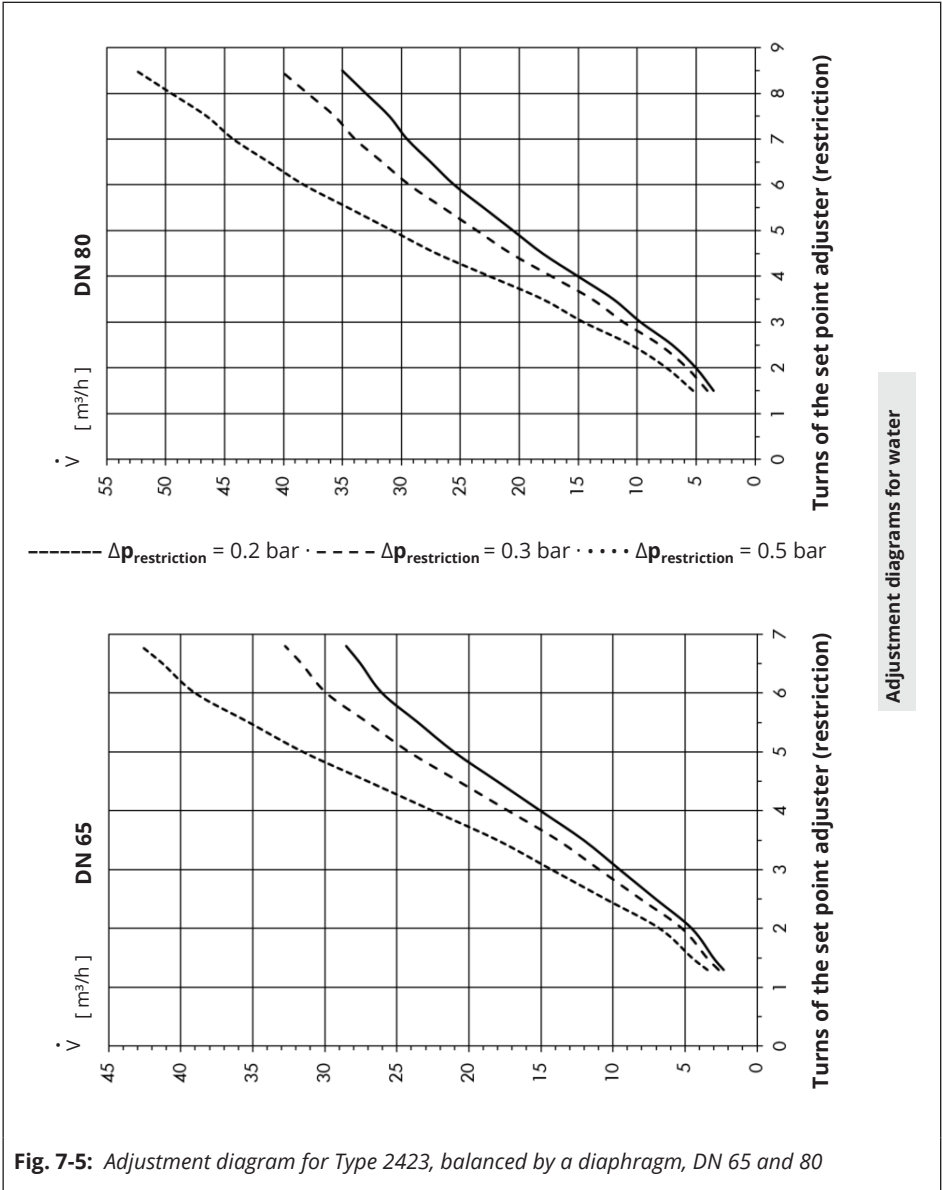


Fig. 7-5: Adjustment diagram for Type 2423, balanced by a diaphragm, DN 65 and 80

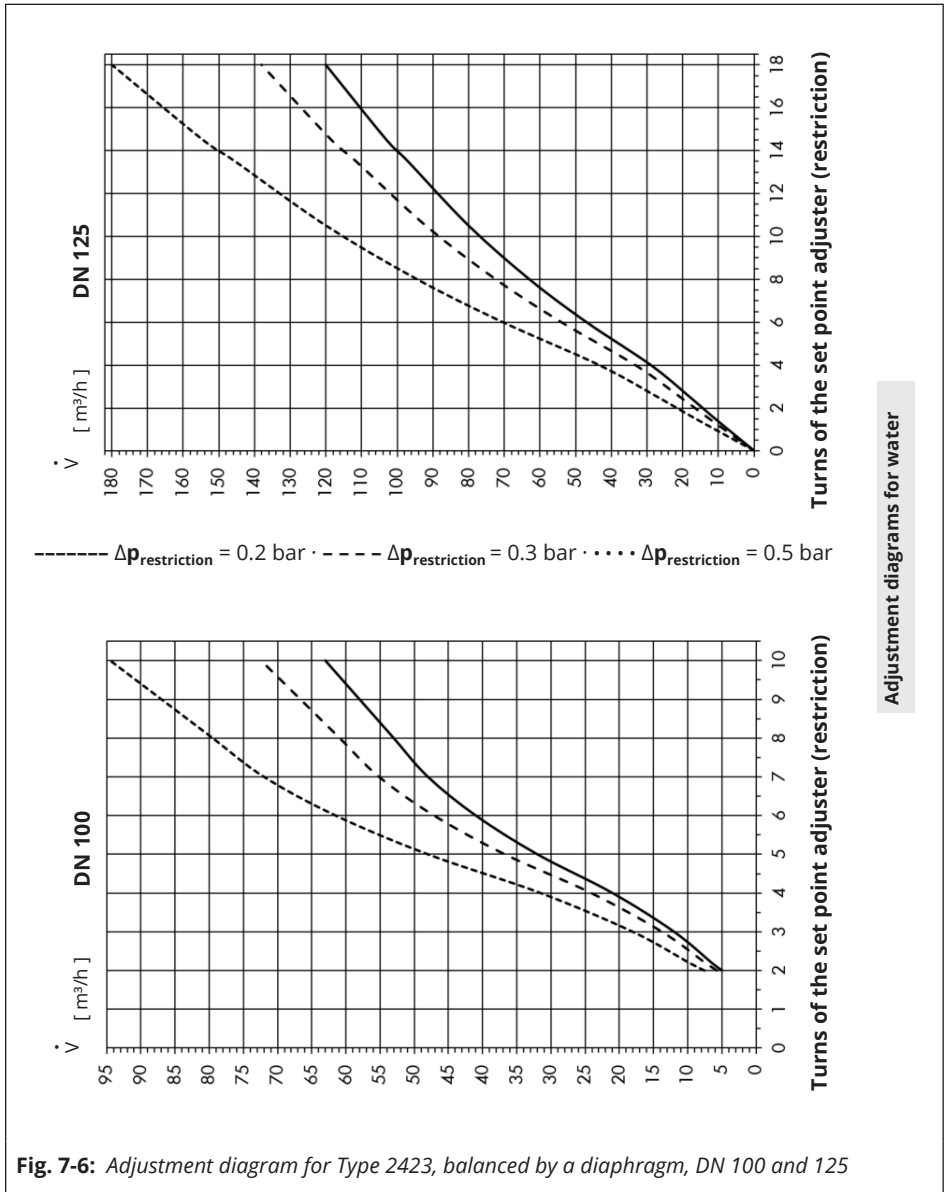


Fig. 7-6: Adjustment diagram for Type 2423, balanced by a diaphragm, DN 100 and 125

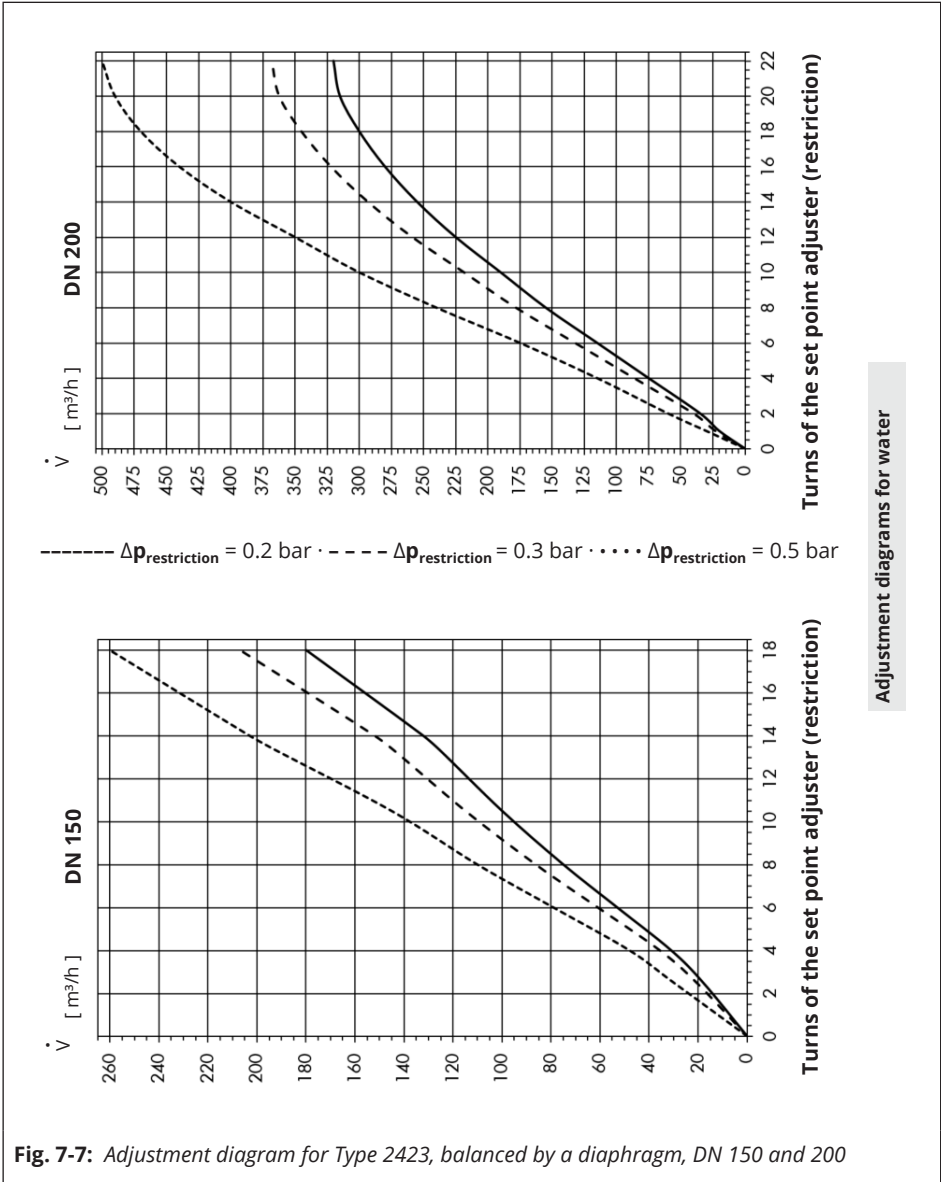


Fig. 7-7: Adjustment diagram for Type 2423, balanced by a diaphragm, DN 150 and 200

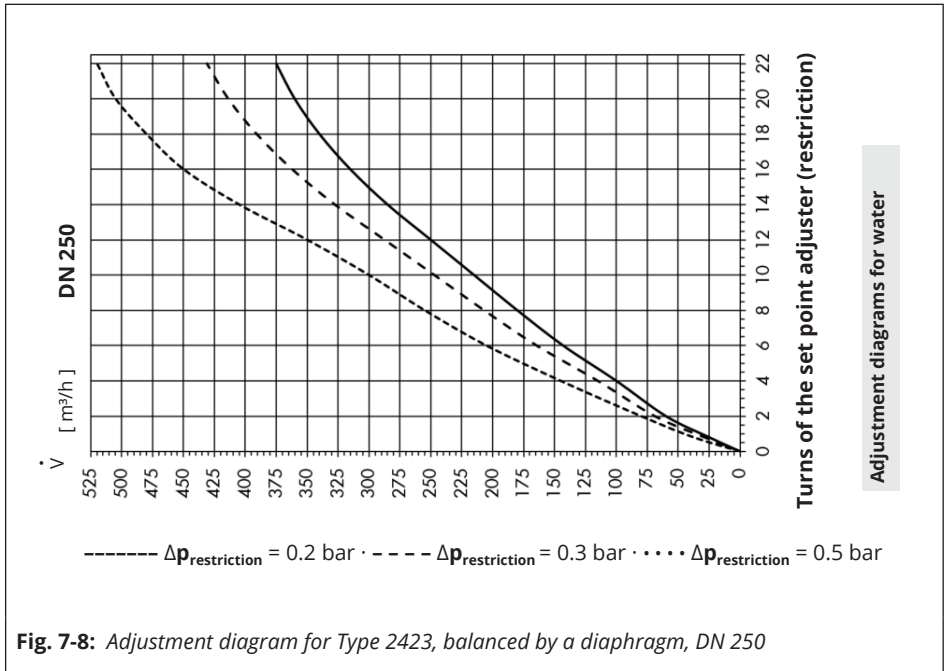


Fig. 7-8: Adjustment diagram for Type 2423, balanced by a diaphragm, DN 250

### 7.3 Adjusting the differential pressure set point of the Type 2427 Actuator (Type 42-37)

- ➔ Before adjusting the differential pressure, close the shut-off valve on the consumer side or the bypass to reduce the flow rate to approx. 5 %. If you are using a motorized valve, close it to approx. 10 % of its travel.
- ➔ Set the differential pressure set point by turning the set point adjuster (17) for differential pressure counterclockwise (↺). To do this, compare the pressures upstream and downstream of the consumer at the reading of the installed pressure gauges. If small differential pressure set points are to be adjusted, we recommend using a differential pressure gauge instead of the two pressure gauges.

Turn the set point adjuster (17) clockwise (↻) to increase the differential pressure set point and counterclockwise (↺) to reduce the differential pressure set point.

### 7.4 Adjusting the pressure set point of the Type 2429 Actuator (Type 42-39)

Adjust the pressure set point at the set point adjuster for pressure (22). While doing so, observe the downstream pressure at the installed pressure gauge. Turn the set point adjuster (22) clockwise (↻) to increase the pressure set point and counterclockwise (↺) to reduce the pressure set point.

## 8 Malfuncions

### 8.1 Troubleshooting

Malfunction	Possible reasons	Recommended action
Flow rate, differential pressure or pressure exceeds adjusted set point	Insufficient pressure pulses on the operating diaphragm	→ Clean the control line and screw fittings.
	Foreign particles blocking the plug	→ Remove foreign particles. → Replace damaged parts. → Contact SAMSON's After-sales Service.
	Seat and plug are worn or leak.	→ Replace the damaged seat and plug. → Contact SAMSON's After-sales Service.
	Valve too large for control task (flow rate) or too small (differential pressure)	→ Check the sizing. → Change $K_{VS}/C_V$ coefficient, if necessary or install a different sized regulator. → Contact SAMSON's After-sales Service.
	Defective operating diaphragm	→ Replace damaged diaphragm.
Flow rate, differential pressure or pressure set point not reached	Regulator installed against the flow	→ Install the regulator so that the direction of flow matches the direction indicated by the arrow on the body.
	Regulator or $K_{VS}/C_V$ coefficient too small	→ Check the sizing. → Change $K_{VS}/C_V$ coefficient, if necessary or install a different sized regulator. → Contact SAMSON's After-sales Service.
	Incorrect set point range selected	→ Check set point range → Contact SAMSON's After-sales Service.
	Safety device, e.g. pressure limiter, has been triggered	→ Check plant. If necessary, unlock safety device.
	Plant differential pressure $\Delta p$ too low	→ Compare differential pressure in the plant with the plant's drag. Differential pressure across the plant: $\Delta p_{\min} = \Delta p_{\text{restriction}} + (\dot{V}/K_{VS})^2$
	Foreign particles blocking the plug	→ Remove foreign particles. → Replace damaged parts. → Contact SAMSON's After-sales Service.

## Malfunctions

Malfunction	Possible reasons	Recommended action
Flow rate, differential pressure or pressure set point not reached	Control line blocked	→ Clean the control line and screw fittings.
	Strainer blocked	→ Clean the strainer.
	Defective operating diaphragm	→ Replace damaged diaphragm.
Control loop hunts	Regulator or $K_{Vs}/C_v$ coefficient too large	<ul style="list-style-type: none"> <li>→ Check the sizing.</li> <li>→ Change <math>K_{Vs}/C_v</math> coefficient, if necessary or install a different sized regulator.</li> <li>→ Contact SAMSON's After-sales Service.</li> </ul>
	The restriction or needle valve in the control line for pressure tapping is too large or missing.	<ul style="list-style-type: none"> <li>→ Install a restriction.</li> <li>→ Install a smaller restriction.</li> <li>→ Do not completely close the needle valve.</li> </ul>
Slow control response	Restriction in the screw joint of the actuator dirty or too small	→ Clean screw joint or install larger screw joint.
	Dirt in the control line	→ Clean the control line.
Jerky control response	Increased friction, e.g. due to foreign particles between seat and plug	<ul style="list-style-type: none"> <li>→ Remove foreign particles.</li> <li>→ Replace damaged parts.</li> <li>→ Contact SAMSON's After-sales Service.</li> </ul>
Loud noises	High flow velocity, cavitation	<ul style="list-style-type: none"> <li>→ Check the sizing.</li> <li>→ Install larger regulator, if necessary.</li> </ul>
Leakage at the actuator	Defective operating diaphragm	→ Replace damaged diaphragm.

### **i** Note

Contact SAMSON's After-sales Service for malfunctions not listed in the table.



The malfunctions listed in Chapter 8.1 are caused by mechanical faults and incorrect regulator sizing. In the simplest case, the functioning can be restored following the recommended action. Special tools may be required to rectify the fault.

Exceptional operating and installation conditions may lead to changed situations that may affect the control response and lead to malfunctions. For troubleshooting, the conditions, such as installation, process medium, temperature and pressure conditions, must be taken into account.

**Tip**

*SAMSON's After-sales Service can support you in drawing up an inspection and test plan for your plant.*

---

## 8.2 Emergency action

Plant operators are responsible for emergency action to be taken in the plant.

SAMSON recommends removing the regulator from the pipeline before repairing it.

In the event of a regulator malfunction:

1. Close the shut-off valves upstream and downstream of the regulator to stop the process medium from flowing through the regulator.
2. Perform troubleshooting (see Chapter 8.1).
3. Rectify those malfunctions that can be remedied following the information given in this document. Contact SAMSON's After-sales Service in all other cases.

### **Putting the device back into operation after a malfunction**

See the 'Start-up' chapter.



## 9 Servicing

The regulator does not require much maintenance. Nevertheless, it is subject to natural wear, particularly at the seat, plug and operating diaphragm. Depending on the operating conditions, check the regulator at regular intervals to avoid possible malfunctions. Plant operators are responsible for drawing up an inspection and test plan. Details on faults and how to remedy them can be found in the 'Malfunctions' chapter.

The work described in this chapter is to be performed only by personnel appropriately qualified to carry out such tasks.

SAMSON recommends removing the regulator from the pipeline before performing any maintenance or service work.

### **⚠ DANGER**

***Danger due to suspended loads falling.***

- ➔ *Stay clear of suspended or moving loads.*
- ➔ *Close off and secure the transport paths.*

### **⚠ WARNING**

***Risk of personal injury due to residual process medium in the regulator.***

*While working on the regulator, residual process medium can escape and, depending on its properties, may lead to personal injury, e.g. (chemical) burns.*

- ➔ *Wear protective clothing, safety gloves and eye protection.*

### **⚠ WARNING**

***Risk of personal injury due to the regulator tipping.***

- ➔ *Observe the regulator's center of gravity.*
- ➔ *Secure the regulator against tipping over or turning.*

### **⚠ WARNING**

***Risk of burn injuries due to hot or cold components and pipeline.***

*Regulator components and the pipeline may become very hot or cold. Risk of burn injuries.*

- ➔ *Allow components and pipelines to cool down or warm up to the ambient temperature.*
- ➔ *Wear protective clothing and safety gloves.*

### **⚠ WARNING**

***Risk of lifting equipment tipping over and risk of damage to lifting accessories due to exceeding the rated lifting capacity.***

- ➔ *Only use approved lifting equipment and accessories whose minimum lifting capacity is higher than the weight of the valve (including actuator and packing, if applicable).*
- ➔ *Refer to the 'Design and principle of operation' chapter for the weights.*

---

### **WARNING**

#### **Risk of injury due to incorrect lifting without the use of lifting equipment.**

Lifting the regulator without the use of lifting equipment may lead to injuries (back injuries in particular) depending on the weight of the regulator and/or actuator.

- ➔ Observe the occupational health and safety regulations valid in the country of use.
  - ➔ Observe the guideline weight for manual handling: 15 to max. 55 kg per person taking into account age, gender and physical fitness.
  - ➔ When the actuator is filled with medium, take the weight of the medium also into account.
  - ➔ Refer to the 'Design and principle of operation' chapter for the weights of the regulator and actuator.
- 

---

### **NOTICE**

#### **Risk of regulator damage due to the use of unsuitable tools.**

- ➔ Only use tools approved by SAMSON (see the 'Tools' chapter in the Appendix).
- 

---

### **NOTICE**

#### **Risk of regulator damage due to the use of unsuitable lubricants.**

- ➔ Only use lubricants approved by SAMSON (see the 'Lubricants' chapter in the Appendix).
- 

---

### **NOTICE**

#### **Risk of regulator damage due to over- or under-torquing.**

Observe the specified torques when tightening regulator components. Excessive tightening torques lead to parts wearing out more quickly. Parts that are too loose may cause leakage.

- ➔ Observe the specified tightening torques (see the 'Tightening torques' chapter in the Appendix).
- 

---

### **Note**

#### **The regulator was checked by SAMSON before it left the factory.**

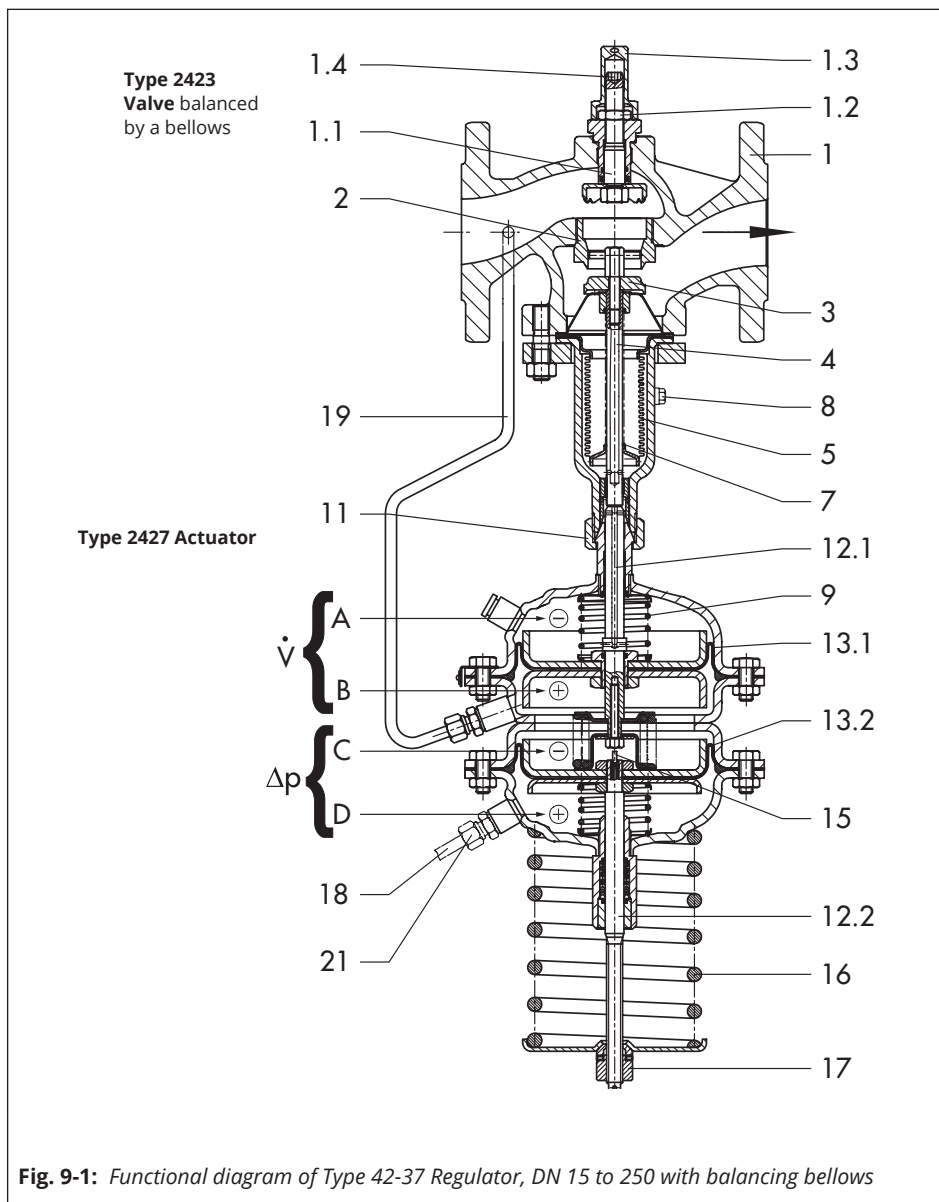
- Certain test results certified by SAMSON lose their validity when the regulator is opened. Such testing includes seat leakage and leak tests.
  - The product warranty becomes void if service or repair work not described in these instructions is performed without prior agreement by SAMSON's After-sales Service.
  - Only use original spare parts by SAMSON, which comply with the original specifications.
- 

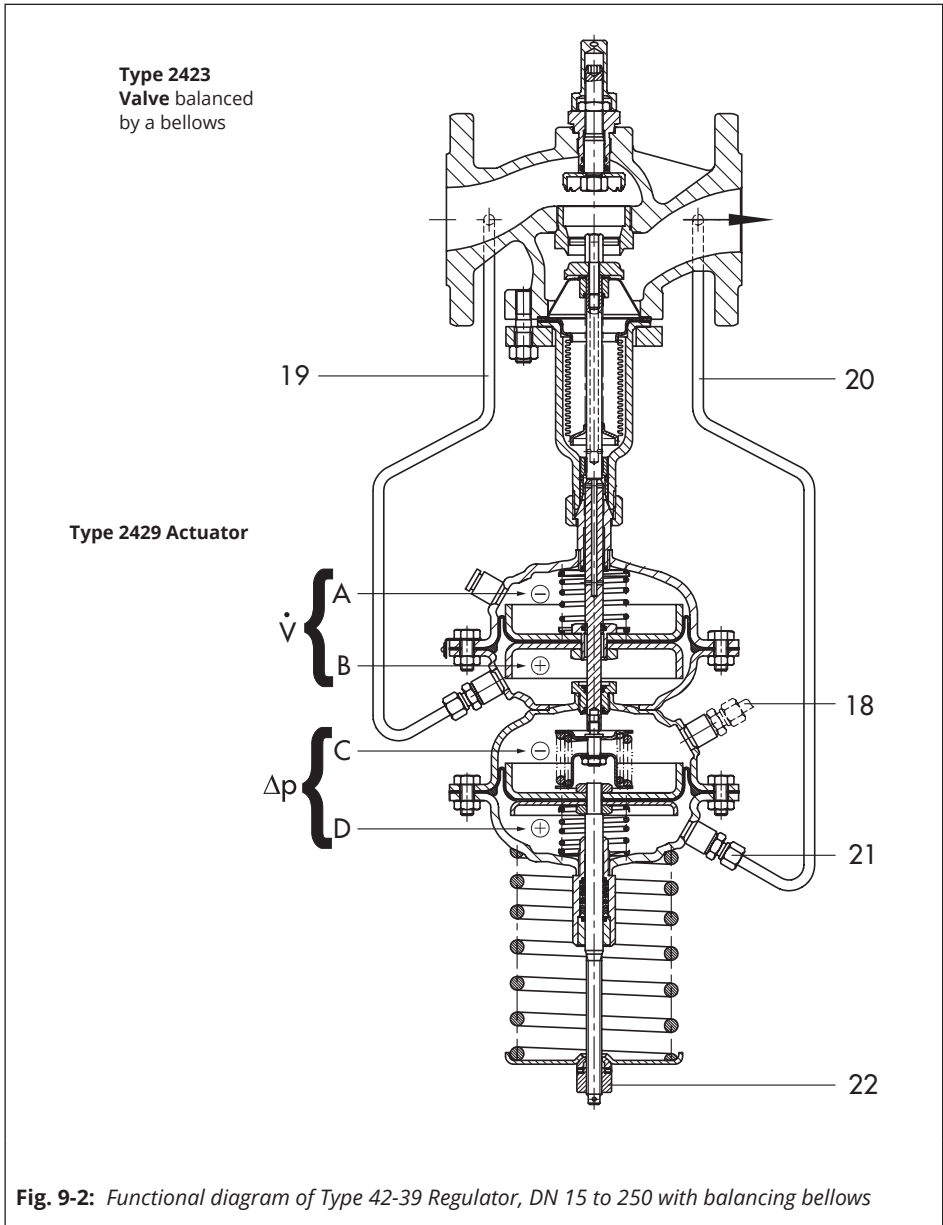
---

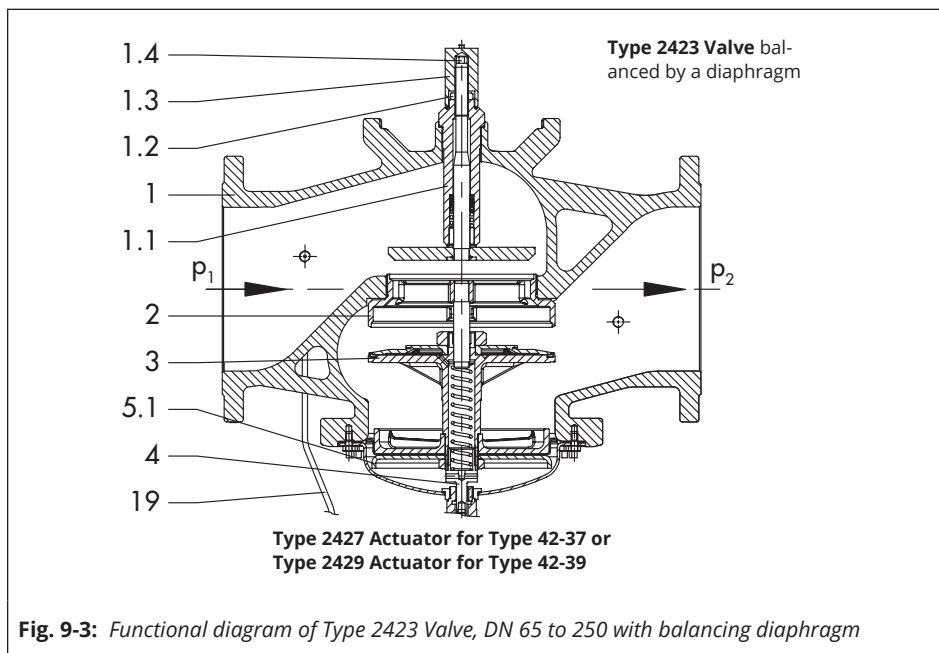
### **Tip**

SAMSON's After-sales Service can support you in drawing up an inspection and test plan for your plant.

---







**Legend for Fig. 9-1 to Fig. 9-3**

1	Valve body	8	Vent plug (DN 125 and larger)	16	Set point spring
1.1	Restriction	9	Differential pressure spring	17	Set point adjuster (differential pressure)
1.2	Lock nut	11	Coupling nut	18	Control line (to be provided on site)
1.3	Cap	12.1	Top diaphragm stem	19	Control line (+) V
1.4	Set point adjuster for flow rate	12.2	Bottom diaphragm stem	20	Control line (+) $\Delta p$
2	Seat	13.1	Top operating diaphragm	21	Restriction to dampen signal
3	Plug	13.2	Bottom operating diaphragm	22	Set point adjuster (pressure)
4	Plug stem	15	Overload protection		
5	Balancing bellows				
5.1	Balancing diaphragm				
7	Spring				

### 9.1 Service work preparations

1. Lay out the necessary material and tools to have them ready for the service work.
2. Put the regulator out of operation (see the 'Decommissioning' chapter).



#### Tip

*SAMSON recommends removing the regulator from the pipeline before performing any service work (see the 'Removing the regulator from the pipeline' chapter).*

---

The following service work can be performed after preparation is completed:

- Replace the actuator (see Chapter 9.3.1)
- Replace the seat and plug (see Chapter 9.3.2)
- Replace the actuator's operating diaphragm (see Chapter 9.3.3)

### 9.2 Installing the regulator after service work

- Put the regulator back into operation (see the 'Start-up' chapter). Make sure the requirements and conditions for start-up or putting the device back into operation are met.

### 9.3 Service work

- Before performing any service work, preparations must be made to the regulator (see Chapter 9.1).
- After all service work is completed, check the regulator before putting it back into operation (see section 'Testing the regulator' in the 'Installation' chapter).



### 9.3.1 Replacing the actuator

→ See Fig. 9-1 to Fig. 9-3

#### Removing the actuator

1. Put the regulator out of operation (see the 'Decommissioning' chapter).
2. Unscrew the control line (18 to 20).
3. Unscrew the coupling nut (11) of the diaphragm actuator from the valve. Remove the actuator.

#### Mounting the actuator

1. Place the diaphragm actuator on the valve and tighten the coupling nut (11). Observe the specified tightening torques (see the 'Tightening torques' chapter in the Appendix).
2. Screw on the control line (18 to 20). Observe the specified tightening torques (see the 'Tightening torques' chapter in the Appendix).
3. Put the regulator into operation (see the 'Start-up' chapter).

### 9.3.2 Replacing the seat and plug

To replace seat and plug, contact SAMSON's After-sales Service.

Further information is available in the 'After-sales service' chapter in the Appendix.

### 9.3.3 Replacing the actuator's operating diaphragm

To replace the operating diaphragm, contact SAMSON's After-sales Service.

Further information is available in the 'After-sales service' chapter in the Appendix.

### **9.4 Ordering spare parts and operating supplies**

Contact your nearest SAMSON subsidiary or SAMSON's After-sales Service for information on spare parts, lubricants and tools.

#### **Spare parts**

See the Appendix for details on spare parts.

#### **Lubricants**

Contact SAMSON's After-sales Service for more information on lubricants.

#### **Tools**

Contact SAMSON's After-sales Service for more information on tools.

## 10 Decommissioning

The work described in this chapter is to be performed only by personnel appropriately qualified to carry out such tasks.

### **⚠ DANGER**

**Risk of bursting due to incorrect opening of pressurized equipment or components.**

Regulators and pipelines are pressure equipment that may burst when handled incorrectly. Flying projectile fragments or the release of process medium under pressure can cause serious injury or even death.

Before working on the regulator:

- Depressurize all plant sections concerned and the regulator.
- Drain the process medium from the plant sections affected as well as from the valve.

### **⚠ WARNING**

**Risk of burn injuries due to hot or cold components and pipeline.**

Regulator components and the pipeline may become very hot or cold. Risk of burn injuries.

- Allow components and pipelines to cool down or warm up to the ambient temperature.
- Wear protective clothing and safety gloves.

### **⚠ WARNING**

**Risk of personal injury due to pressurized components and as a result of process medium being discharged.**

Incorrect opening of pressure equipment or mounting parts may lead to the process medium escaping to the atmosphere.

- Do not unscrew the control line while the valve is pressurized.
- Do not start up the regulator until all parts have been mounted.

### **⚠ WARNING**

**Risk of hearing loss or deafness due to loud noise.**

Noise emission (e.g. cavitation) may occur during operation caused by the process medium and the operating conditions.

- Wear hearing protection when working near the valve. Follow the instructions given by the plant operator.

### **⚠ WARNING**

**Crush hazard arising from moving parts.**

- Do not insert hands or fingers between the set point springs while the regulator is in operation.
- Do not insert hands or fingers between the pillars and set point springs while the regulator is in operation.
- Do not insert hands or fingers between the spring plate and crossbeam while the regulator is in operation.

## Decommissioning

→ Before starting any work on the regulator, depressurize plant sections as well as the regulator.

---

### **WARNING**

#### **Risk of personal injury due to residual process medium in the regulator.**

While working on the regulator, residual process medium can escape and, depending on its properties, may lead to personal injury, e.g. (chemical) burns.

→ Wear protective clothing, safety gloves and eye protection.

---

To put the regulator out of operation for service work or before removing it from the pipeline, proceed as follows:

1. Close the shut-off valve (1) on the upstream side of the regulator.
2. Close the shut-off valve (6) on the downstream side of the regulator.
3. Depressurize the plant.
4. Completely drain the pipelines and valve.
5. Unscrew the control line (18 to 20).
6. If necessary, allow the pipeline and regulator components to cool down or warm up to the ambient temperature.

## 11 Removal

The work described in this chapter is to be performed only by personnel appropriately qualified to carry out such tasks.

### **⚠ WARNING**

#### ***Risk of burn injuries due to hot or cold components and pipeline.***

*Regulator components and the pipeline may become very hot or cold. Risk of burn injuries.*

- *Allow components and pipelines to cool down or warm up to the ambient temperature.*
- *Wear protective clothing and safety gloves.*

### **⚠ WARNING**

#### ***Risk of personal injury due to residual process medium in the regulator.***

*While working on the regulator, residual process medium can escape and, depending on its properties, may lead to personal injury, e.g. (chemical) burns.*

- *Wear protective clothing, safety gloves and eye protection.*

Before removing, make sure that the following conditions are met:

- The regulator is put out of operation (see the 'Decommissioning' chapter).

### 11.1 Removing the regulator from the pipeline

1. Support the regulator to hold it in place when separated from the pipeline (see the 'Shipment and on-site transport' chapter).
2. Unbolt the flanged joint.
3. Remove the regulator from the pipeline (see the 'Shipment and on-site transport' chapter).

### 11.2 Removing the actuator from the valve

See the 'Servicing' chapter.



## 12 Repairs

If the regulator does not function properly according to how it was originally sized or does not function at all, it is defective and must be repaired or exchanged.

### **!** NOTICE

**Risk of regulator damage due to incorrect service or repair work.**

- Do not perform any repair work on your own.
- Contact SAMSON's After-sales Service for service and repair work.

### 12.1 Returning devices to SAMSON

Defective devices can be returned to SAMSON for repair.

Proceed as follows to return devices:

1. Exceptions apply concerning some special device models
  - ▶ [www.samsongroup.com](http://www.samsongroup.com) > Service > After-sales Service.
2. Send an e-mail ▶ [retouren@samsongroup.com](mailto:retouren@samsongroup.com) to register the return shipment including the following information:

- Type
- Material number
- Item numbers of accessories
- Original order
- Completed Declaration on Contamination, which can be downloaded from our website at
  - ▶ [www.samsongroup.com](http://www.samsongroup.com) > Service > After-sales Service.

**After checking your registration, we will send you a return merchandise authorization (RMA).**

3. Attach the RMA (together with the Declaration on Decontamination) to the outside of your shipment so that the documents are clearly visible.
4. Send the shipment to the address given on the RMA.

### **i** Note

*Further information on returned devices and how they are handled can be found at*

- ▶ [www.samsongroup.com](http://www.samsongroup.com) > Service > After-sales Service.





## 13 Disposal



SAMSON is a producer registered in Europe, agency in charge ► <https://www.samsongroup.com/en/about-samson/environment-social-governance/material-compliance/waste-electrical-and-electronic-equipment-veee-and-its-safe-disposal/>. WEEE reg. no.: DE 62194439

Information on substances listed as substances of very high concern (SVHC) on the candidate list of the REACH regulation can be found in the document "Additional Information on Your Inquiry/Order", which is added to the order documents, if applicable. This document includes the SCIP number assigned to the devices concerned. This number can be entered into the database on the European Chemicals Agency (ECHA) website (► <https://www.echa.europa.eu/scip-database>) to find out more information on the SVHC contained in the device.

### **i** Note

*SAMSON can provide you with a recycling passport on request. Simply e-mail us at [aftersalesservice@samsongroup.com](mailto:aftersalesservice@samsongroup.com) giving details of your company address.*

### **💡** Tip

*On request, SAMSON can appoint a service provider to dismantle and recycle the product as part of a distributor take-back scheme.*

- ➔ Observe local, national and international refuse regulations.
- ➔ Do not dispose of components together with your other household waste.



## 14 Certificates

The EU declarations of conformity are included on the next pages:

- EU declaration of conformity in compliance with Pressure Equipment Directive 2014/68/EU on page 14-2.
- EU declaration of conformity in compliance with Machinery Directive 2006/42/EC for Type 42-37 and Type 42-39 Regulators on page 14-8.
- Declaration of incorporation in compliance with Machinery Directive 2006/42/EC for the Type 2423 Valve with Type 2427 and Type 2429 Actuator on page 14-10.

EU DECLARATION OF CONFORMITY  
TRANSLATION



Module A

For the following products, SAMSON hereby declares under its sole responsibility:

Devices	Series	Type	Version
Self-operated Regulators	43	2432	DIN EN, body, CC499K and EN-GJS-400-18-LT, DN 50, PN 25, fluids G2, L2, L1 <sup>1)</sup>
	43	2436	DIN EN, body, CC499K and EN-GJS-400-18-LT, DN 50, PN 25, fluids G2, L2, L1 <sup>1)</sup>
	43	2437	DIN EN, body, CC499K and EN-GJS-400-18-LT, DN 50, PN 25, fluids G2, L2, L1 <sup>1)</sup>
	---	2111	DIN EN, body, EN-GJS-400-18-LT, DN 50, PN 25, fluids G2, L2, L1 <sup>1)</sup> DIN EN, body, 1.0619 and 1.4408, DN 40-50, PN 40, fluids G2, L2, L1 <sup>1)</sup> ANSI, body, A216 WCC and A351 CF8M, NPS 1½-2, Class 300, fluids G2, L2, L1 <sup>1)</sup>
Three-way valve	---	2119	DIN EN, body, EN-GJL-250 and 1.0619, DN 65-125, PN 16, fluids G2, L2, L1 <sup>1)</sup>
			DIN EN, body, 1.0619, DN 50-80, PN 25, fluids G2, L2, L1 <sup>1)</sup>
			DIN EN, body, 1.0619 and 1.4408, DN 40-50, PN 40, fluids G2, L2, L1 <sup>1)</sup>
			ANSI, body, A216 WCC and A351 CF8M, NPS 2½-4, Class 150, fluids G2, L2, L1 <sup>1)</sup> ANSI, body, A216 WCC and A351 CF8M, NPS 1½, Class 300, fluids G2, L2, L1 <sup>1)</sup>
Control valve	---	3222	DIN EN, body, EN-GJS-400-18-LT, DN 50, PN 25, fluids G2, L2, L1 <sup>1)</sup>
			DIN EN, body, CC499K, DN 32-40, PN 25, all fluids
Three-way valve	---	3226	DIN EN, body, CC499K, DN 50, PN 25, fluids G2, L2 <sup>2)</sup>
Three-way valve	---	3260	DIN EN, body, EN-GJL-250, DN 65-200, PN 16, fluids G2, L2 <sup>2)</sup>
Globe valve Three-way valve	V2001	3531	DIN EN, body, EN-GJS-400-18-LT, DN 50-80, PN 25, fluids G2, L2, L1 <sup>1)</sup>
		3535	DIN EN, body, 1.0619 and 1.4408, DN 32-40, PN 25, all fluids ANSI, body, A216 WCC and A351 CF8M, NPS 1½-2, Class 150, all fluids
Control valve	---	3214	DIN EN, body, EN-GJL-250, DN 65-125, PN 16, fluids G2, L2, L1 <sup>1)</sup>
			DIN EN, body, EN-GJS-400-18-LT, DN 50-80, PN 25, fluids G2, L2, L1 <sup>1)</sup>
			ANSI, body, A126 B, NPS 3-4, Class 125, fluids G2, L2, L1 <sup>1)</sup>
			ANSI, body, A216 WCC and A351 CF8M, NPS 1½-2, Class 150, all fluids
Self-operated Regulators	42	2423	DIN EN, body, EN-GJL-250 and EN-GJS-400-18-LT, DN 65-125, PN 16, fluids G2, L2, L1 <sup>1)</sup>
			DIN EN, body, EN-GJS-418-LT, DN 50-80, PN 25, fluids G2, L2, L1 <sup>1)</sup>
			DIN EN, body, 1.0619 and 1.4408, DN 32-50, PN 16, all fluids
			DIN EN, body, 1.0619 and 1.4408, DN 32-40, PN 25, all fluids ANSI, body, A126 B, NPS 3-4, Class 125, fluids G2, L2, L1 <sup>1)</sup>
	42	2422	DIN EN, body, EN-GJL-250 and EN-GJS-400-18-LT, DN 65-125, PN 16, fluids G2, L2, L1 <sup>1)</sup>
			DIN EN, body, EN-GJS-400-18-LT, DN 50-80, PN 25, fluids G2, L2, L1 <sup>1)</sup>
			DIN EN, body, 1.0619, 1.4408 and 1.6220+QT, DN 32-50, PN 16, all fluids
			ANSI, body, A126 B, NPS 3-4, Class 125, fluids G2, L2, L1 <sup>1)</sup> ANSI, body, A216 WCC, A351 CF8M and A352 LCC, NPS 1½-2, Class 150, all fluids
Strainers	1N/1NI	2601	DIN EN, body, CB752S, G 2 (DN50), PN25, fluids G2, L2 <sup>2)</sup>
Strainers	2N/2NI	2602	DIN EN, body, EN-GJL-250, DN 200-250, PN 10, fluids G2, L2, L1 <sup>1)</sup>
			DIN EN, body, EN-GJL-250, DN 65-125, PN 16, fluids G2, L2, L1 <sup>1)</sup>
			DIN EN, body, EN-GJS-400-18-LT, DN 100-125, PN 16, fluids G2, L2, L1 <sup>1)</sup>
			DIN EN, body, EN-GJS-400-18-LT, DN 50-80, PN 25, fluids G2, L2, L1 <sup>1)</sup> DIN EN, body, 1.4408, DN 32-50, PN 16, all fluids
Self-operated Regulators	---	2373/2375	ANSI, body, A995 4A and A995 5A, NPS 1½-2, Class 150, all fluids
		2440 (44-0B) 2441 (44-1B) 2440 (44-8B)	DIN EN, body, EN-GJS-400-18-LT, DN 50, PN 25, fluids G2, L2, L1 <sup>1)</sup>
	44	2442 (44-2) 2443 (44-3) 2444 (44-4) 2447 (44-7) 2449 (44-9)	DIN EN, body, EN-GJS-400-18-LT and CC499K, DN 50, PN 25, fluids G2, L2, L1 <sup>1)</sup>

Revision 01

EU DECLARATION OF CONFORMITY  
TRANSLATION



Devices	Series	Type	Version
Self-operated Regulators	45	2451 (45-1)	DIN EN, body, EN-GJS-400-18-LT and CC499K, DN 50, PN 25, fluids G2, L2, L1 <sup>1)</sup>
		2452 (45-2)	
		2453 (45-3)	
		2454 (45-4)	
		2456 (45-6)	
	46	2465 (46-5)	DIN EN, body, EN-GJS-400-18-LT and CC499K, DN 50, PN 25, fluids G2, L2, L1 <sup>1)</sup>
		2486 (46-6)	
		2487 (46-7)	
		2469 (46-9)	
	47	2471 (47-1)	DIN EN, body, EN-GJS-400-18-LT and CC499K, DN 50, PN 25, fluids G2, L2, L1 <sup>1)</sup>
		2474 (47-4)	
		2475 (47-5)	
	48	2488	DIN EN, body, EN-GJS-400-18-LT and CC499K, DN 50, PN 25, fluids G2, L2, L1 <sup>1)</sup>
		2489	
	40	2405	DIN EN, body, EN-GJS-400-18-LT, DN 50, PN 25, fluids G2, L2, L1 <sup>1)</sup>
			ANSI, body, A216 WCC and A351 CF8M, NPS 1½-2, Class 150, all fluids
		2406	DIN EN, body, EN-GJL-250, DN 65-125, PN 16, fluids G2, L2, L1 <sup>1)</sup>
			DIN EN, body, EN-GJS-400-18-LT, DN 50, PN 25, fluids G2, L2, L1 <sup>1)</sup>
	41	2412	ANSI, body, A126 B, NPS 3-4, Class 125, fluids G2, L2, L1 <sup>1)</sup>
			DIN EN, body, EN-GJL-250, DN 65-100, PN 16, fluids G2, L2, L1 <sup>1)</sup>
		2417	DIN EN, body, EN-GJS-400-18-LT, DN 50-80, PN 25, fluids G2, L2, L1 <sup>1)</sup>
			ANSI, body, A216 WCC and A351 CF8M, NPS 1½-2, Class 150, all fluids
	42	2421 RS	DIN EN, body, 1.0619, 1.4408, 1.4571 and 1.4401/1.4404, DN 32-50, PN 16, all fluids
			DIN EN, body, 1.0619, 1.4408, 1.4571 and 1.4401/1.4404, DN 32-40, PN 25, all fluids
			ANSI, body, A216 WCC, A351 CF8M and A182 F316/A182 F316L, NPS 1½-2, Class 150, all fluids
	---	2331	DIN EN, body, EN-GJL-250, DN 65-200, PN 16, fluids G2, L2 <sup>2)</sup>
			DIN EN, body, EN-GJS-400-18-LT, DN 65-150, PN 16, fluids G2, L2 <sup>2)</sup>
			DIN EN, body, EN-GJS-400-18-LT, DN 65-125, PN 25, fluids G2, L2 <sup>2)</sup>
DIN EN, body 1.0619, DN 65-200, PN 16, fluids G2, L2 <sup>2)</sup>			
DIN EN, body 1.0619, DN 65-100, PN 40, fluids G2, L2 <sup>2)</sup>			
---	2337	DIN EN, body 1.0619, DN 250, PN 25, fluids L1 <sup>1)</sup>	
		DIN EN, body 1.0619, DN 250, PN 40, fluids L1 <sup>1)</sup>	
---	2333	DIN EN, body, EN-GJL-250, DN 65-125, PN 16, fluids G2, L2, L1 <sup>1)</sup>	
		DIN EN, body, EN-GJS-400-18-LT, DN 65-80, PN 25, fluids G2, L2, L1 <sup>1)</sup>	
---	2335	ANSI, body, A126 B, NPS 3-4, Class 125, fluids G2, L2, L1 <sup>1)</sup>	
		DIN EN, body, EN-GJL-250, DN 65-125, PN 16, fluids G2, L2, L1 <sup>1)</sup>	
		DIN EN, body, EN-GJS-400-18-LT, DN 65-125, PN 16, fluids G2, L2, L1 <sup>1)</sup>	
		ANSI, body, A126 B, NPS 3-4, Class 125, fluids G2, L2, L1 <sup>1)</sup>	
---	2334	DIN EN, body, EN-GJS-400-18-LT, DN 65-80, PN 25, fluids G2, L2, L1 <sup>1)</sup>	
		DIN EN, body, EN-GJS-400-18-LT, DN 65-125, PN 16, fluids G2, L2, L1 <sup>1)</sup>	
		ANSI, body, A126 B, NPS 3-4, Class 125, fluids G2, L2, L1 <sup>1)</sup>	
---	2404-1	DIN EN, body, EN-GJL-250, DN 65-125, PN16, fluids G2, L2, L1 <sup>1)</sup>	
		ANSI, body, A126 B, NPS 3-4, Class 125, fluids G2, L2, L1 <sup>1)</sup>	
---	2404-2	ANSI, body, A216 WCC und A351 CF8M, NPS 1½-2, Class 150, all fluids	
		DIN EN, body, EN-GJL-250, DN 65-125, PN 16, fluids G2, L2, L1 <sup>1)</sup>	
		ANSI, body, A126 B, NPS 3-4, Class 125, fluids G2, L2, L1 <sup>1)</sup>	

<sup>1)</sup> Gases according to Article 4(1)(c.i), second indent  
Liquids according to Article 4(1)(c.ii)

<sup>2)</sup> Gases according to Article 4(1)(c.i), second indent  
Liquids according to Article 4(1)(c.ii), second indent

## EU DECLARATION OF CONFORMITY TRANSLATION



That the products mentioned above comply with the requirements of the following standards:

Directive of the European Parliament and of the Council on the harmonization of the laws of the Member States relating to the making available on the market of pressure equipment	2014/68/EU	of 15. May 2014
Applied conformity assessment procedure for fluids according to Article 4(1)	Module A	

Technical standards applied: DIN EN 12516-2, DIN EN 12516-3, ASME B16.34

Manufacturer: SAMSON AG, Weismüllerstraße 3, 60314 Frankfurt am Main, Germany

Frankfurt am Main, 05. June 2024

pp. Norbert Tollas  
Senior Vice President  
Global Operations

i.V. Peter Scheermesser  
Director  
Product Maintenance & Engineered Products

Revision 01

Classification: Public · SAMSON AKTIENGESELLSCHAFT · Weismüllerstraße 3 · 60314 Frankfurt am Main, Germany Page 3 of 3

EU DECLARATION OF CONFORMITY  
TRANSLATION



**Module H / N° CE-0062-PED-H-SAM 001-22-DEU-rev-A**

For the following products, SAMSON hereby declares under its sole responsibility:

Devices	Series	Type	Version	
Three-way valve	---	2119	DIN EN, body, EN-GJL-250 and 1.0619, DN 150, PN 16, fluids G2, L2, L1 <sup>1)</sup>	
			DIN EN, body, 1.0619, DN 100-150, PN 25, fluids G2, L2, L1 <sup>1)</sup>	
			DIN EN, body, 1.0619 and 1.4408, DN 65-150, PN 40, fluids G2, L2, L1 <sup>1)</sup>	
			ANSI, body, A216 WCC and A351 CF8M, NPS 6, Class 150, fluids G2, L2, L1 <sup>1)</sup>	
			ANSI, body, A216 WCC and A351 CF8M, NPS 2-6, Class 300, fluids G2, L2, L1 <sup>1)</sup>	
Self-operated Regulators	---	3222	DIN EN, body, CC499K, DN 50, PN 25, all fluids	
Three-way valve	---	3260	DIN EN, body, EN-GJL-250, DN 250-300, PN 16, fluids G2, L2 <sup>1)</sup>	
Globe valve Three-way valve	V2001	3531	DIN EN, body, 1.0619 and 1.4408, DN 50-80, PN 25, all fluids	
		3535	ANSI, body, A216 WCC and A351 CF8M, NPS 2½-3, Class 150, all fluids	
Control valve	---	3214	DIN EN, body, EN-GJL-250, DN 150-400, PN 16, fluids G2, L2, L1 <sup>1)</sup>	
			DIN EN, body, 1.0619, DN 32-400, PN 40, all fluids	
			DIN EN, body, EN-GJS-400-18-LT, DN 100-150, PN 25, fluids G2, L2, L1 <sup>1)</sup>	
			ANSI, body, A126 B, NPS 6-10, Class 125, fluids G2, L2, L1 <sup>1)</sup>	
			ANSI, body, A216 WCC, NPS 2½-10, Class 150, all fluids	
Self-operated Regulators	42	2423	ANSI, body, A216 WCC, NPS 1½-10, Class 300, all fluids	
			DIN EN, body, EN-GJL-250, DN 150-250, PN 16, fluids G2, L2, L1 <sup>1)</sup>	
			DIN EN, body, EN-GJS-400-18-LT, DN 150, PN 16, fluids G2, L2, L1 <sup>1)</sup>	
			DIN EN, body, EN-GJS-400-18-LT, DN 100-150, PN 25, fluids G2, L2, L1 <sup>1)</sup>	
			DIN EN, body, 1.0619 and 1.4408, DN 65-250, PN 16, all fluids	
			DIN EN, body, 1.0619 and 1.4408, DN 50-250, PN 25, all fluids	
			DIN EN, body, 1.0619 and 1.4408, DN 32-250, PN 40, all fluids	
			ANSI, body, A126 B, NPS 6-10, Class 125, fluids G2, L2, L1 <sup>1)</sup>	
			ANSI, body, A216 WCC and A351 CF8M, NPS 2½-10, Class 150, all fluids	
			ANSI, body, A216 WCC and A351 CF8M, NPS 1½-10, Class 300, all fluids	
			DIN EN, body, EN-GJL-250, DN 150-400, PN 16, fluids G2, L2, L1 <sup>1)</sup>	
			DIN EN, body, EN-GJS-400-18-LT, DN 100-150, PN 25, fluids G2, L2, L1 <sup>1)</sup>	
			DIN EN, body, 1.0619 and 1.4408, DN 65-400, PN 16, all fluids	
			DIN EN, body, 1.0619 and 1.4408, DN 200-400, PN 25, all fluids	
			DIN EN, body, 1.0619 and 1.4408, DN 32-400, PN 40, all fluids	
	DIN EN, body, 1.0460, DN 40-50, PN 40, all Fluids			
	DIN EN, body, 1.6220+QT, DN 65-250, PN 16, all fluids			
	DIN EN, body, 1.6220+QT, DN 200-250, PN 25, all fluids			
	DIN EN, body, 1.6220+QT, DN 32-250, PN 40, all fluids			
	ANSI, body, A126 B, NPS 6-16, Class 125, fluids G2, L2, L1 <sup>1)</sup>			
	ANSI, body, A216 WCC and A351CF8M, NPS 2½-16, Class 150, all fluids			
	ANSI, body, A216 WCC and A351CF8M, NPS 1½-16, Class 300, all fluids			
	ANSI, body, A105, NPS 1½-2, Class 300, all fluids			
	ANSI, body, A352 LCC, NPS 2½-10, Class 150, all fluids			
	ANSI, body, A352 LCC, NPS 1½-10, Class 300, all fluids			
	DIN EN, body, 1.0619 and 1.4408, DN 65-150, PN 16, all fluids			
	DIN EN, body, 1.0619 and 1.4408, DN 50-150, PN 25, all fluids			
	DIN EN, body, 1.0619 and 1.4408, DN 32-150, PN 40, all fluids			
	DIN EN, body, 1.4571 and 1.4401/1.4404, DN 50, PN 25, all fluids			
	DIN EN, body, 1.4571 and 1.4401/1.4404, DN 32-50, PN 40, all fluids			
	ANSI, body, A216 WCC and A351 CF8M, NPS 2½-6, Class 150, all fluids			
	ANSI, body, A216 WCC and A351 CF8M, NPS 1½-6, Class 300, all fluids			
	Self-operated Regulators	42	2421RS	DIN EN, body, 1.0619 and 1.4408, DN 65-150, PN 16, all fluids
				DIN EN, body, 1.0619 and 1.4408, DN 50-150, PN 25, all fluids
				DIN EN, body, 1.0619 and 1.4408, DN 32-150, PN 40, all fluids

Revision 01

Classification: Public · SAMSON AKTIENGESELLSCHAFT · Weismuellerstrasse 3 · 60314 Frankfurt am Main, Germany

Page 1 of 3

EU DECLARATION OF CONFORMITY  
TRANSLATION



Devices	Series	Type	Version		
Self-operated Regulators	40	2405	DIN EN, body, 1.0619, 1.4571, 1.4404, 1.4408, 1.0460, DN 32-50, PN40, all fluids		
			ANSI, body, A105, A182 F316L, A351 CF8M, A216 WCC, NPS 1½-2, Class 300, all fluids		
		2406	DIN EN, body, EN-GJL-250, DN 150, PN 16, fluids G2, L2, L1 <sup>1)</sup>		
			DIN EN, body, 1.0619 and 1.4408, DN 32-150, PN 40, all fluids		
			DIN EN, body, 1.0460 and 1.4404, DN 32-50, PN 40, all fluids		
			ANSI, body, A128 B, NPS 6, Class 125, fluids G2, L2, L1 <sup>1)</sup>		
	41	2412	ANSI, body, A218 WCC and A351 CF8M, NPS 2½-6, Class 150, all fluids		
			ANSI, body, A216 WCC and A351 CF8M, NPS 1½-6, Class 300, all fluids		
		2417	ANSI, body, A105 and A182 F316L, NPS 1½-2, Class 300, all fluids		
			DIN EN, body, EN-GJS-400-18-LT, DN 100, PN25, fluids G2, L2, L1 <sup>1)</sup>		
			DIN EN, body, 1.0619 and 1.4408, DN 32-100, PN 40, all fluids		
			DIN EN, body, 1.0460, 1.4571 and 1.4404, DN 32-80, PN 40, all fluids		
	---	2404-1	ANSI, body, A216 WCC and A351 CF8M, NPS 2½-4, Class 150, all fluids		
			ANSI, body, A216 WCC and A351 CF8M, NPS 1½-4, Class 300, all fluids		
		---	2404-2	ANSI, body, A105 and A182 F316L, NPS 1½-3, Class 300, all fluids	
				DIN EN, body, EN-GJL-250, DN 150, PN16, fluids G2, L2, L1 <sup>1)</sup>	
			---	2331	DIN EN, body, 1.0619 und 1.4408, DN 65-400, PN 16, all fluids
					DIN EN, body, 1.0619 und 1.4408, DN 65-400, PN 16, all fluids
	---	2333	DIN EN, body, EN-GJL-250, DN 150-400, PN 16, fluids G2, L2, L1 <sup>1)</sup>		
			DIN EN, body, EN-GJS-400-18-LT, DN 100-150, PN 25, fluids G2, L2, L1 <sup>1)</sup>		
		---	2335	DIN EN, body, 1.0619 and 1.4408, DN 65-400, PN 16, all fluids	
				DIN EN, body, 1.0619 and 1.4408, DN 200-400, PN 25, all fluids	
		---	2334	DIN EN, body, 1.0619 and 1.4408, DN 65-400, PN 40, all fluids	
				ANSI, body, A126 B, NPS 6-16, Class 125, fluids G2, L2, L1 <sup>1)</sup>	
			---	2373	ANSI, body, A216 WCC and A351 CF8M, NPS 2½-16, Class 150, all fluids
					ANSI, body, A216 WCC and A351 CF8M, NPS 2½-16, Class 300, all fluids
					DIN EN, body, EN-GJL-250, DN 150-400, PN 16, fluids G2, L2, L1 <sup>1)</sup>
					DIN EN, body, EN-GJS-400-18-LT, DN 100-150, PN 25, fluids G2, L2, L1 <sup>1)</sup>
		Strainers	2N/2NI	2602	DIN EN, body, 1.0619 and 1.4408, DN 65-400, PN 16, all fluids
					DIN EN, body, 1.0619 and 1.4408, DN 200-400, PN 25, all fluids
---	2375		2375	DIN EN, body, 1.0619 und 1.4408, DN 65-400, PN 16, all fluids	
				DIN EN, body, 1.0619 und 1.4408, DN 65-400, PN 16, all fluids	
	---		2375	2375	ANSI, body, A126 B, NPS 6-16, Class 125, fluids G2, L2, L1 <sup>1)</sup>
					ANSI, body, A216 WCC and A351 CF8M, NPS 2½-16, Class 150, all fluids
---	2375	2375	ANSI, body, A216 WCC and A351 CF8M, NPS 2½-16, Class 300, all fluids		
			DIN EN, body, EN-GJL-250, DN 150-400, PN 16, fluids G2, L2, L1 <sup>1)</sup>		
---	2375	2375	DIN EN, body, EN-GJS-400-18-LT, DN 100-150, PN 25, fluids G2, L2, L1 <sup>1)</sup>		
			DIN EN, body, EN-GJS-400-18-LT, DN 100-150, PN 25, fluids G2, L2, L1 <sup>1)</sup>		

Revision 01



EU DECLARATION OF CONFORMITY  
TRANSLATION



Devices	Series	Type	Version
Strainers	2N/2NI	2602	DIN EN, body, 1.0619, DN 200-250, PN 25, all fluids
			DIN EN, body, 1.0619, DN 32-250, PN 40, all fluids
			DIN EN, body, 1.4408, DN 65-100, PN 16, all fluids
			DIN EN, body, 1.4408, DN 32-100, PN 40, all fluids

<sup>1)</sup> Gases according to Article 4(1)(c.i), second indent  
Liquids according to Article 4(1)(c.i)

That the products mentioned above comply with the requirements of the following standards:

Directive of the European Parliament and of the Council on the harmonization of the laws of the Member States relating to the making available on the market of pressure equipment	2014/68/EU	of 15. May 2014
Applied conformity assessment procedure for fluids according to Article 4(1)	Module H	by Bureau Veritas 0062

The manufacturer's quality management system is monitored by the following notified body:  
**Bureau Veritas Services SAS, 4 place des Saisons, 92400 Courbevoie, France**  
Technical standards applied: DIN EN 12516-2, DIN EN 12516-3, ASME B16.34

Manufacturer: SAMSON AG, Weismuellerstrasse 3, 60314 Frankfurt am Main, Germany

Frankfurt am Main, 05. June 2024

*ppc. C. Tollas*

ppa. Norbert Tollas  
Senior Vice President  
Global Operations

*i. V. P. Scheermesser*

i.V. Peter Scheermesser  
Director  
Product Maintenance & Engineered Products

Revision 01

Classification: Public · SAMSON AKTIENGESELLSCHAFT · Weismuellerstrasse 3 · 60314 Frankfurt am Main, Germany

Page 3 of 3

## EU DECLARATION OF CONFORMITY TRANSLATION



### Declaration of Conformity of Final Machinery

in accordance with Annex II, section 1.A. of the Directive 2006/42/EC

For the following product:

#### **Type 42-37 Flow and Differential Pressure Regulator consisting of Type 2423 Valve and Type 2427 Actuator**

We hereby declare that the machinery mentioned above complies with all applicable requirements stipulated in Machinery Directive 2006/42/EC.

For product descriptions refer to:

- Type 42-37 Flow and Differential Pressure Regulator:  
Mounting and Operating Instructions EB 3017

Referenced technical standards and/or specifications:

- VCI, VDMA, VGB: "Leitfaden Maschinenrichtlinie (2006/42/EG) – Bedeutung für Armaturen, Mai 2018" [German only]
- VCI, VDMA, VGB: "Zusatzdokument zum Leitfaden Maschinenrichtlinie (2006/42/EG) – Bedeutung für Armaturen vom Mai 2018" [German only], based on DIN EN ISO 12100:2011-03

Comment:

Information on residual risks of the machinery can be found in the mounting and operating instructions of the valve and actuator as well as in the referenced documents listed in the mounting and operating instructions.

Persons authorized to compile the technical file:

SAMSON AG, Weismüllerstraße 3, 60314 Frankfurt am Main, Germany  
Frankfurt am Main, 12 May 2022

A handwritten signature in blue ink, appearing to read "ppc. C. Tollas".

Norbert Tollas  
Senior Vice President  
Global Operations

A handwritten signature in blue ink, appearing to read "i. v. P. Scheermesser".

Peter Scheermesser  
Director  
Product Maintenance & Engineered Products

Revision no. 00



## DECLARATION OF INCORPORATION TRANSLATION



### Declaration of Incorporation in Compliance with Machinery Directive 2006/42/EC

For the following product:  
**Type 2423 Valve**

We certify that the Type 2423 Valve is partly completed machinery as defined in the Machinery Directive 2006/42/EC and that the safety requirements stipulated in Annex I, 1.1.2, 1.1.3, 1.1.5, 1.3.2, 1.3.4 and 1.3.7 are observed. The relevant technical documentation described in Annex VII, part B has been compiled.

Products we supply must not be put into service until the final machinery into which it is to be incorporated has been declared in conformity with the provisions of the Machinery Directive 2006/42/EC.

Operators are obliged to install the products observing the accepted industry codes and practices (good engineering practice) as well as the mounting and operating instructions. Operators must take appropriate precautions to prevent hazards that could be caused by the process medium and operating pressure in the valve as well as by the signal pressure and moving parts.

The permissible limits of application and mounting instructions for the products are specified in the associated mounting and operating instructions; the documents are available in electronic form on the Internet at [www.samsongroup.com](http://www.samsongroup.com).

For product descriptions refer to:

- Type 42-34 and Type 42-38 Differential Pressure Regulators with Flow Limitation:  
Mounting and Operating Instructions EB 3013
- Type 42-36 Flow Regulator: Mounting and Operating Instructions EB 3015
- Type 42-36 E Pressure-independent Control Valve (PICV):  
Mounting and Operating Instructions EB 3018
- Type 42-37 Flow and Differential Pressure Regulator as well as Type 42-39 Flow and Differential Pressure or Pressure Regulator: Mounting and Operating Instructions EB 3017

Referenced technical standards and/or specifications:

- VCI, VDMA, VGB: "Leitfaden Maschinenrichtlinie (2006/42/EG) – Bedeutung für Armaturen, Mai 2018" [German only]
- VCI, VDMA, VGB: "Zusatzdokument zum Leitfaden Maschinenrichtlinie (2006/42/EG) – Bedeutung für Armaturen vom Mai 2018" [German only], based on DIN EN ISO 12100:2011-03

Comments:

- See mounting and operating instructions for residual hazards.
- Also observe the referenced documents listed in the mounting and operating instructions.

Persons authorized to compile the technical file:

SAMSON AG, Weismüllerstraße 3, 60314 Frankfurt am Main, Germany  
Frankfurt am Main, 10 November 2021

Stephan Giesen  
Director  
Product Management

Peter Scheermesser  
Director  
Product Life Cycle Management and ETO  
Development for Valves and Actuators

Revision no. 00

DECLARATION OF INCORPORATION  
TRANSLATION



**Declaration of Incorporation in Compliance with Machinery Directive 2006/42/EC**

For the following product:

**Type 2427 Actuator**

We certify that the Type 2427 Actuator is partly completed machinery as defined in the Machinery Directive 2006/42/EC and that the safety requirements stipulated in Annex I, 1.1.2, 1.1.3, 1.1.5, 1.3.2, 1.3.4 and 1.3.7 are observed. The relevant technical documentation described in Annex VII, part B has been compiled.

Products we supply must not be put into service until the final machinery into which it is to be incorporated has been declared in conformity with the provisions of the Machinery Directive 2006/42/EC.

Operators are obliged to install the products observing the accepted industry codes and practices (good engineering practice) as well as the mounting and operating instructions. Operators must take appropriate precautions to prevent hazards that could be caused by the process medium and operating pressure in the valve as well as by the signal pressure and moving parts.

The permissible limits of application and mounting instructions for the products are specified in the associated mounting and operating instructions; the documents are available in electronic form on the Internet at [www.samsongroup.com](http://www.samsongroup.com).

For product descriptions refer to:

- Type 42-37 Flow and Differential Pressure Regulator: Mounting and Operating Instructions EB 3017

Referenced technical standards and/or specifications:

- VCI, VDMA, VGB: "Leitfaden Maschinenrichtlinie (2006/42/EG) – Bedeutung für Armaturen, Mai 2018" [German only]
- VCI, VDMA, VGB: "Zusatzdokument zum Leitfaden Maschinenrichtlinie (2006/42/EG) – Bedeutung für Armaturen vom Mai 2018" [German only], based on DIN EN ISO 12100:2011-03

Comments:

- See mounting and operating instructions for residual hazards.
- Also observe the referenced documents listed in the mounting and operating instructions.

Persons authorized to compile the technical file:

SAMSON AG, Weismüllerstraße 3, 60314 Frankfurt am Main, Germany  
Frankfurt am Main, 12 May 2022

Stephan Giesen  
Director  
Product Management

Peter Scheermesser  
Director  
Product Maintenance & Engineered Products

Revision no. 00

Classification: Public · SAMSON AKTIENGESELLSCHAFT · Weismüllerstraße 3 · 60314 Frankfurt, Germany

Page 1 of 1



## 15 Appendix

### 15.1 Tightening torques

**Table 15-1:** *Tightening torque*

Part	Width across flats	Valve size/ actuator area	Tightening torque in Nm
Cap (1.3)	A/F 30	DN 15 to 100	20
	A/F 36	DN 125 to 250	40
Coupling nuts (11)	A/F 36	All	120
Control line connection (18...20)	-	40 to 640 cm <sup>2</sup>	22
Stopper (35, 50, 53)	G ¼	DN 15 to 100	50
	G 3/8	DN 125 to 250	70

### 15.2 Lubricants

SAMSON's After-sales Service can support you concerning lubricants and sealants approved by SAMSON.

### 15.3 Tools

SAMSON's After-sales Service can support you concerning tools approved by SAMSON.

### 15.4 Accessories

**Table 15-2:** *Assignment of compensation chamber (18) to regulator, with item no.*

Type 2426 Actuator Actuator area A	Item number Compensation chamber	
	DN 15 to 50	DN 65 to 100
640 cm <sup>2</sup>	1190-8789	1190-8790
320 cm <sup>2</sup>	1190-8788	1190-8789
160, 80, 40 cm <sup>2</sup>	1190-8788	

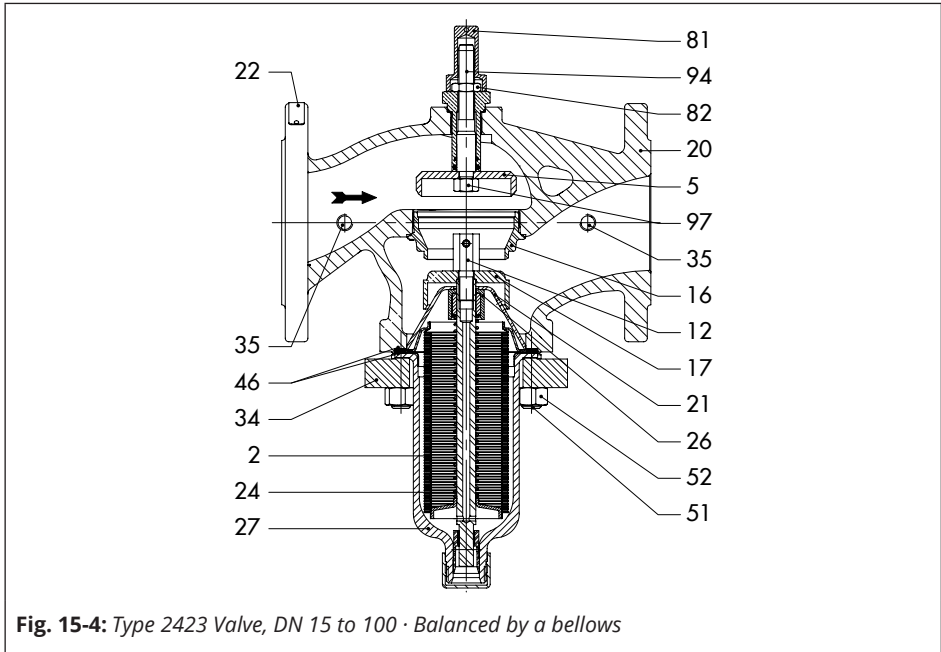
**Table 15-3:** *Stopper to seal the control line connection in the valve body*

Type 2423 Valve	Item number	
	G ¼	G ¾
Stopper	8323-005200040	8323-0073
Seal	8412-0771	8412-0782

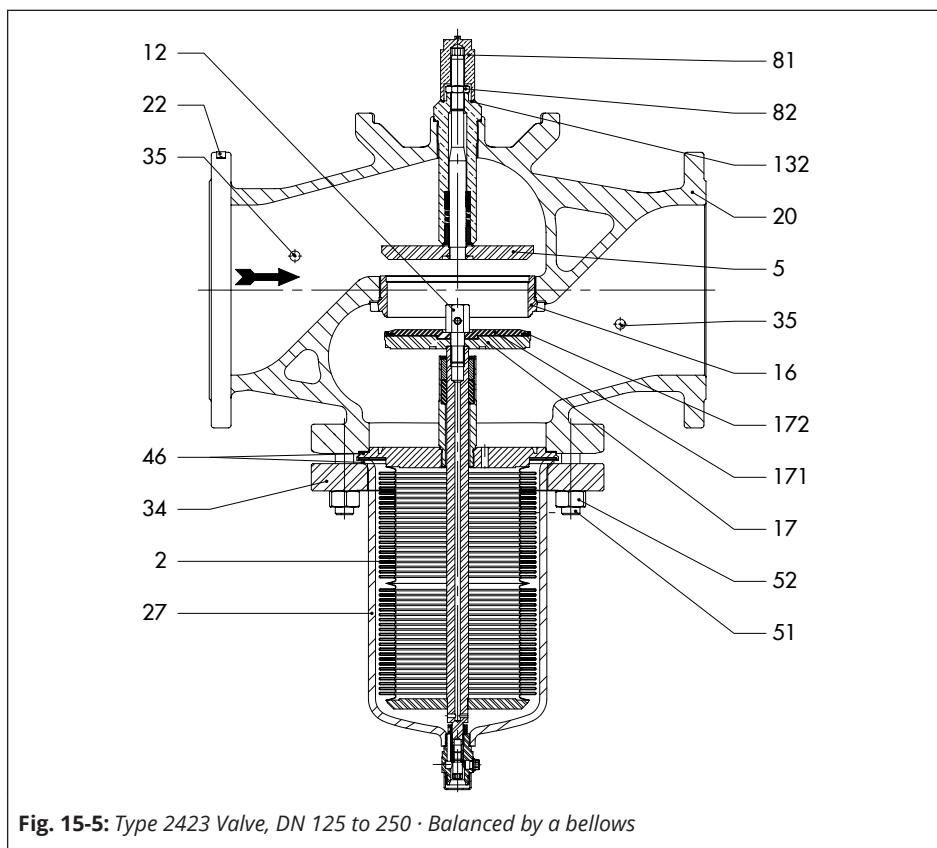
## 15.5 Spare parts

### Legend for Fig. 15-2 and Fig. 15-1

2	Bellows	35	Screw plug
5	Restriction	46	Graphite seal on metal core
12	Screw	51	Stud
16	Seat	52, 82	Hex nut
17	Plug	81	Cap
20	Body	132	O-ring
21	Guide cap	171	Clamping ring
22	Label	172	Seal
24	Compression spring		
26	Guide tube		
27	Bottom section		
34	Flange		







## Appendix

### Legend for Fig. 15-3

5	Restriction	27	Cover
8	Compression spring	34	Ring
10	Diaphragm plate	46	Gasket
11	Diaphragm	51	Stud
12	Castle nut	52, 82	Hex nut
13	Washer	53	Screw plug
14	Plug stem	81	Nut
16	Seat	94	Stem
18	Plug	97	Hex nut (self-locking)
19	Screw		
20	Body		
21	Guide cap		
22	Label		

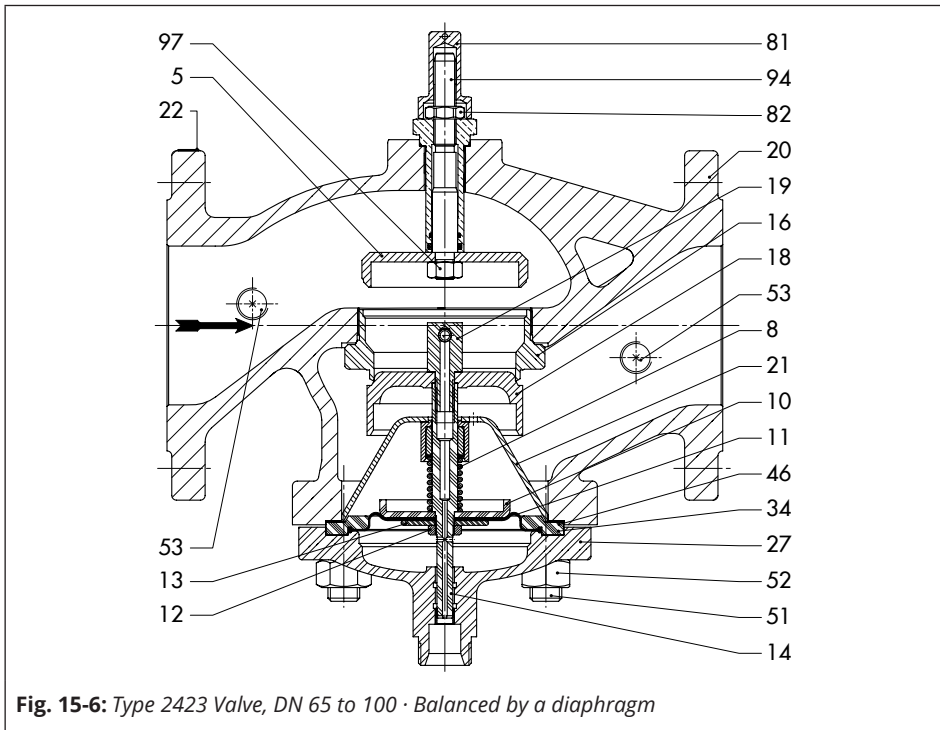
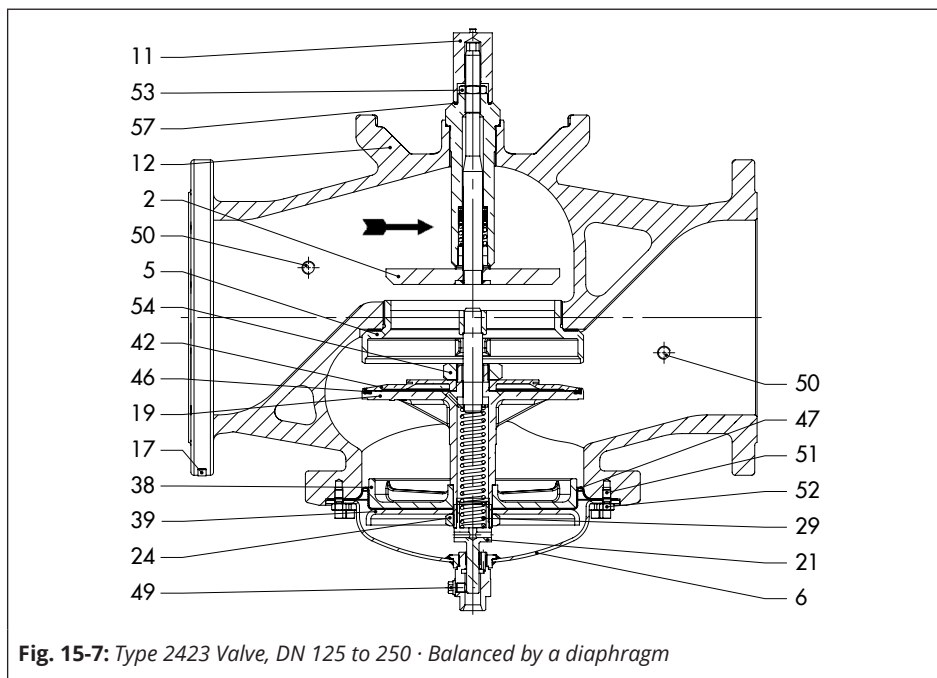


Fig. 15-6: Type 2423 Valve, DN 65 to 100 · Balanced by a diaphragm

**Legend for Fig. 15-4**

2	Restriction	46	Seal
5	Seat	47	Diaphragm
6	Diaphragm case	49, 50	Screw plug
11	Cap	51	Stud
12	Body	52...54	Hex nut
17	Label	57	O-ring
19	Plug		
21	Nipple		
24	Nut		
38, 39	Diaphragm plate		
42	Clamping disk		



## Appendix

### Legend for Fig. 15-6 and Fig. 15-5

1	Diaphragm case with guide nipple and coupling nut	26...28	Compression spring
2	Intermediate piece	29, 30	Diaphragm stem
3	Nipple	32	Diaphragm plate
4	Diaphragm case with guide nipple	39	Spring plate
5	Diaphragm stem with excess pressure relief and diaphragm	41	Screw fitting
6	Force limiter	44	Hex bolt
7	Screw joint with restriction	45	Screw plug
8	Diaphragm	46	Hex nut
10...12	Compression spring	47	Screw fitting
15	Nameplate	49	Axial needle seal with washer
18	Nipple		
20	Diaphragm plate nut		
21	Nut		

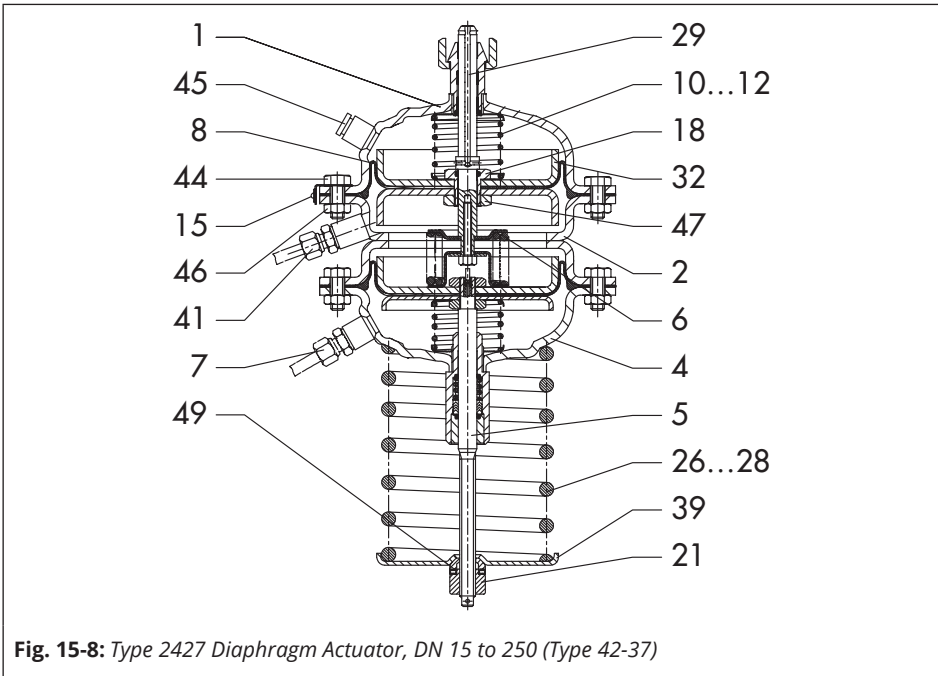
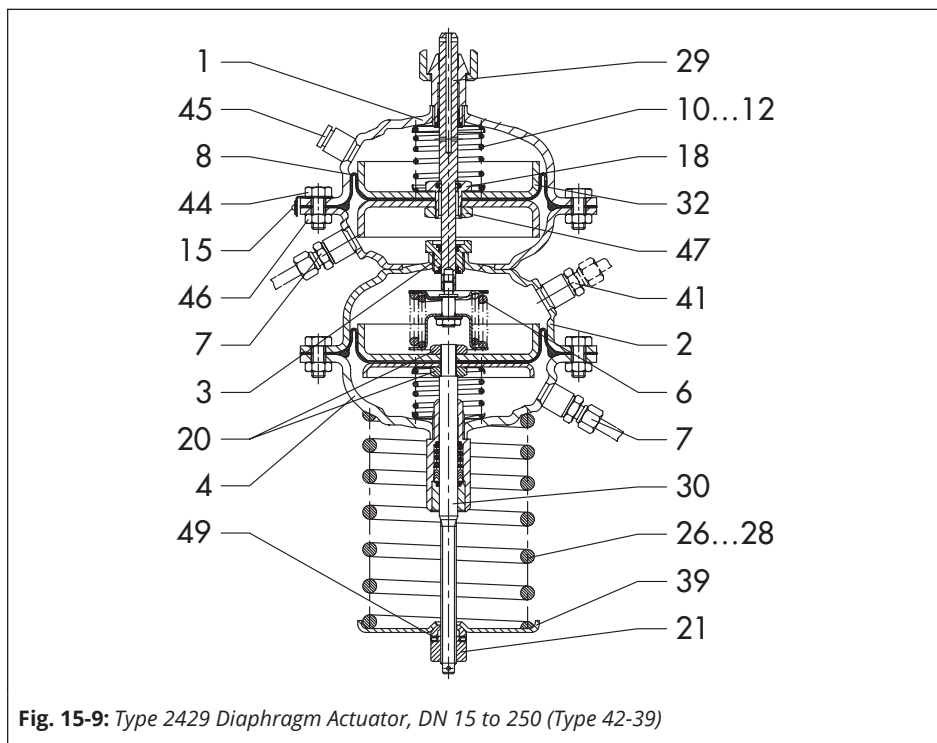


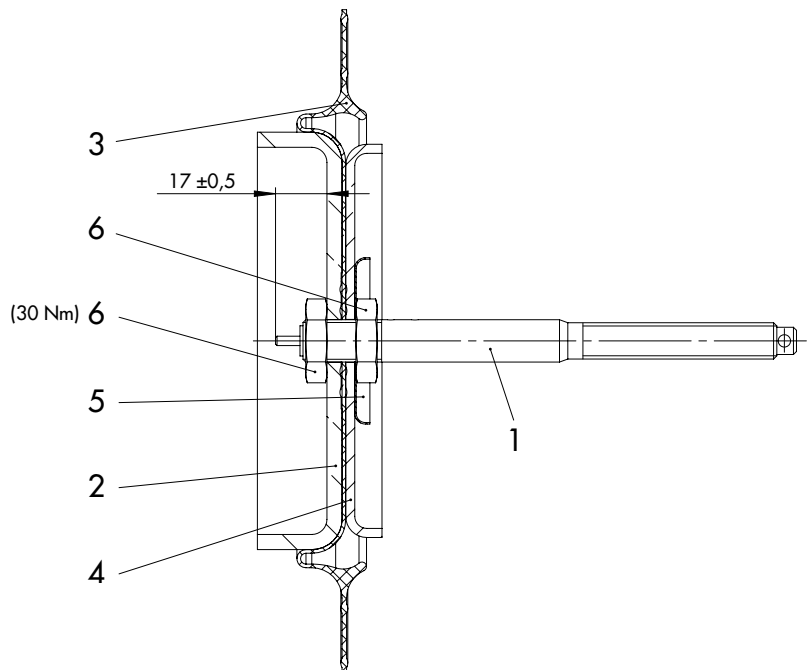
Fig. 15-8: Type 2427 Diaphragm Actuator, DN 15 to 250 (Type 42-37)



## Appendix

### Legend for Fig. 15-7

1	Diaphragm stem	4	Washer
2	Diaphragm plate	5	Spring plate
3	Diaphragm	6	Nut



**Fig. 15-10:** Diaphragm stem, excess pressure limiter and diaphragm · Type 2424 (DN 15 to 250)

## 15.6 After-sales service

Contact SAMSON's After-sales Service for support concerning service or repair work or when malfunctions or defects arise.

### E-mail contact

You can reach our after-sales service at [aftersaleservice@samsongroup.com](mailto:aftersaleservice@samsongroup.com).

### Addresses of SAMSON AG and its subsidiaries

The addresses of SAMSON AG, its subsidiaries, representatives and service facilities worldwide can be found on our website (► [www.samsongroup.com](http://www.samsongroup.com)) or in all SAMSON product catalogs.

## Required specifications

Please submit the following details:

- Device type and nominal size
- Valve balanced by a bellows or diaphragm
- Model number or material number
- Upstream and downstream pressure
- Temperature and process medium
- Min. and max. flow rate in m<sup>3</sup>/h
- Is a strainer installed?
- Installation drawing showing the exact location of the regulator and all the additionally installed components (shut-off valves, pressure gauge etc.)













SAMSON AKTIENGESELLSCHAFT  
Weismüllerstraße 3 · 60314 Frankfurt am Main, Germany  
Phone: +49 69 4009-0 · Fax: +49 69 4009-1507  
samson@samsongroup.com · www.samsongroup.com