



SH 8384-6 EN

Translation of original instructions



Type 3730-6 Electropneumatic Positioner
with pressure sensors, communication: HART®

Edition July 2020



Definition of signal words

DANGER

Hazardous situations which, if not avoided, will result in death or serious injury

WARNING

Hazardous situations which, if not avoided, could result in death or serious injury

NOTICE

Property damage message or malfunction

Note

Additional information

Tip

Recommended action

Purpose of this manual

The Safety Manual SH 8384-6 contains information relevant to the use of the Type 3730-6 Positioner in safety-instrumented systems according to IEC 61508 and IEC 61511. The safety manual is intended for planners, constructors and operators of safety-instrumented systems.

NOTICE

Risk of malfunction due to incorrect mounting, connection or start-up of the positioner.

- ➔ *Refer to Mounting and Operating Instructions EB 8384-6 for details on how to mount the positioner, perform the electric and pneumatic connections as well as start up the positioner.*
 - ➔ *Observe the warnings and safety instructions written in the Mounting and Operating Instructions EB 8384-6.*
-

Further documentation

The documents listed below contain descriptions of the start-up, functioning and operation of the positioner. You can download these documents from the SAMSON website.

Type 3730-6 Positioner with HART® communication

- ▶ T 8384-6: Data sheet
- ▶ EB 8384-6: Mounting and operating instructions
- ▶ KH 8384-3: Configuration manual for HART® communication
- ▶ KA 8384-2: Quick guide

EXPERTplus diagnostics

- ▶ T 8389-1: Data sheet
 - ▶ EB 8389-1: Operating instructions
-

Note

In addition to the positioner documentation, observe the technical documentation for the pneumatic actuator, control valve and other valve accessories.

1	Scope	6
1.1	General	6
1.2	Use in safety-instrumented systems	6
1.3	Versions and ordering data	6
2	Technical data (excerpt from EB 8384-6)	8
3	Safety-related functions	10
3.1	Fail-safe action	10
3.2	Protection against unauthorized changes to the configuration	12
4	Mounting, connection and start-up	12
5	Required conditions	13
5.1	Selection	13
5.2	Mechanical and pneumatic installation	13
5.3	Electrical installation.....	14
5.4	Operation	14
6	Proof testing.....	15
6.1	Visual inspection to avoid systematic failure	15
6.2	Function testing.....	16
7	Maintenance and repair	19
8	Safety-related data and certificates	19

1 Scope

1.1 General

The Type 3730-6 Electropneumatic Positioner is a single-acting, venting positioner with HART® communication for attachment to pneumatic rotary and linear actuators with spring-return mechanism. The positioner is used to position control valves.

1.2 Use in safety-instrumented systems

Observing the requirements of IEC 61508, the systematic capability of the pilot valve for emergency venting as a component in safety-instrumented systems is given.

Use of the positioner is possible on observing the requirements of IEC 61511 and the required hardware fault tolerance in safety-instrumented systems up to SIL 2 (single device/HFT = 0) and SIL 3 (redundant configuration/HFT = 1).

The individual safety-instrumented functions of the positioner are to be regarded as Type A elements in accordance with IEC 61508-2.

1.3 Versions and ordering data

All versions of the Type 3730-6 Positioner are suitable for use in safety-instrumented systems. The positioner can be fitted with options. The options enhance the safety-instrumented functions of the positioner. These options are the **inductive limit switch SJ2-SN**, **solenoid valve and forced venting**.

Furthermore, the **emergency shutdown** affects the failure behavior.

The article code written on the nameplate (see next page) provides details on the optional equipment and the emergency shutdown of the positioner.

Type 3730-6 Positioner			
	x	x	0
Option (additional equipment)			
Without inductive limit switch	0		
With inductive limit switch SJ2-SN (NAMUR NC contact)	1		
Without solenoid valve	0		
With 24 V DC solenoid valve	1		
Forced venting, 24 V DC	2		
Emergency shutdown			
3.8 mA			0
4.4 mA			1

Attachment

The positioner is suitable for the following types of attachment in combination with various mounting parts:

- Direct attachment to SAMSON Type 3277 Linear Actuators
- Attachment to linear actuators according to IEC 60534-6 (NAMUR)
- Attachment to linear actuators according to VDI/VDE 3847
- Attachment to SAMSON Type 3510 Micro-flow Valve
- Attachment to rotary actuators according to VDI/VDE 3845, fixing levels 1 and 2

2 Technical data (excerpt from EB 8384-6)

Type 3730-6 Positioner (technical data in test certificates additionally apply to explosion-protected devices)		
Reference variable w	Signal range	4 to 20 mA · Two-wire device, reverse polarity protection · Minimum span 4 mA
	Static destruction limit	30 V
Minimum current		3.6 mA for display · Emergency venting at <3.8 mA or <4.4 mA
Load impedance		≤9.2 V (corresponding to 460 Ω at 20 mA)
Supply	Supply air	1.4 to 7 bar (20 to 105 psi)
	Air quality acc. to ISO 8573-1 (edition 2001-02)	Maximum particle size and density: Class 4 · Oil content: Class 3 Pressure dew point: Class 3 or at least 10 K below the lowest ambient temperature to be expected
Signal pressure (output)		0 bar up to the supply pressure · Can be limited between 1.4 and 7.0 bar by software
Hysteresis		≤0.3 %
Sensitivity		≤0.1 %
Transit time		Exhaust and supply adjustable separately up to 240 s by software
Air output capacity	Actuator (supply)	At Δp = 6 bar: 8.5 m _n ³ /h · At Δp = 1.4 bar: 3.0 m _n ³ /h · K _{Vmax(20 °C)} = 0.09
	Actuator (exhaust)	At Δp = 6 bar: 14.0 m _n ³ /h · At Δp = 1.4 bar: 4.5 m _n ³ /h · K _{Vmax(20 °C)} = 0.15
Permissible ambient temperature		-20 to +80 °C for all versions -45 to +80 °C with metal cable gland The limits in the type examination certificate additionally apply to explosion-protected versions.
Certified according to IEC 61508/SIL		Suitable for use in safety-instrumented systems up to SIL 2 (single device/HFT = 0) and SIL 3 (redundant configuration/HFT = 1) according to IEC 61511. <ul style="list-style-type: none"> - Triggered by the set point, emergency venting depending on positioner version at <3.8 mA or <4.4 mA - By the optional solenoid valve, emergency venting at 0 V - By the optional forced venting function, emergency venting at <12 V

Safety-relevant options

Electronic forced venting · Approval acc. to IEC 61508/SIL	
Input	24 V DC · Electrical isolation and reverse polarity protection · Static destruction limit 40 V Power draw: $I = \frac{U - 5.7 \text{ V}}{3.84 \text{ k}\Omega}$ (corresponding to 4.8 mA at 24 V/114 mW)
Signal '0' (no response)	<12 V (emergency shutdown at 12 V)
Signal '1' (response)	>19 V
Solenoid valve · Approval acc. to IEC 61508/SIL	
Input	24 V DC · Reverse polarity protection · Static destruction limit 40 V Power draw: $I = \frac{U - 5.7 \text{ V}}{3.84 \text{ k}\Omega}$ (corresponding to 4.8 mA at 24 V/114 mW)
Signal '0' (no response)	<12 V (emergency shutdown at 0 V)
Signal '1' (response)	>19 V
Service life	>5 x 10 ⁶ switching cycles
Inductive limit switch by Pepperl+Fuchs	For connection to switching amplifier acc. to EN 60947-5-6 Can be used in combination with a software limit switch
SJ2-SN proximity switch	Measuring plate not detected: ≥3 mA · Measuring plate detected: ≤1 mA

3 Safety-related functions

Emergency venting over the i/p converter (Fig. 1 path —————)

In automatic mode, the PD controller (3) compares the valve position to the DC control signal issued by the microcontroller. In case of a system deviation, the activation of the i/p converter is changed so that the actuator (1) is either vented or supplied with air. Fail-safe action is triggered when a signal smaller or equal to the shutdown signal (3.8 mA or 4.4 mA, see Chapter 1.3 on page 6) is applied to terminals 11/12 and, as a result, to the i/p converter.

Emergency venting over the optional solenoid valve (Fig. 1 path)

The solenoid valve (12) is energized by a 24 V DC voltage signal. Fail-safe action is triggered and the signal pressure for the air booster (7) is vented to the atmosphere when a 0 V signal is applied to terminals 81/82. As a result, the actuator is vented and the valve moves to its fail-safe position.

Emergency venting over forced venting (Fig. 1 path -----)

The forced venting (25) is energized by a 24 V DC voltage signal. If the voltage signal at terminals 81/82 falls below 12 V, the i/p converter (6) is not activated. The positioner vents the actuator, causing the valve to move to the fail-safe position determined by the actuator, independent of the reference variable.

Safety-related end position monitoring over the optional inductive limit switch

(Fig. 1 path ————)

The inductive limit switch SJ2-SN (NAMUR NC contact) indicates the adjusted safety-related end position at terminals 41/42. See ► EB 8384-6 for adjusting the limit switches.

3.1 Fail-safe action

Fail-safe action is triggered by the i/p converter, solenoid valve or forced venting and upon supply air failure. The positioner fully discharges its pneumatic output to the atmosphere, causing the pneumatic actuator to be vented. As a result, the valve moves to the fail-safe position. The fail-safe position depends on how the springs are arranged in the pneumatic actuator (air-to-close or air-to-open).

When the supply air fails, the optional solenoid valve or forced venting is triggered and after reaching the shutdown signal (3.8 mA or 4.4 mA, see Chapter 1.3 on page 6), all positioner functions, except open/closed loop control, remain active (including diagnostics, HART® communication as well as position and status feedback).

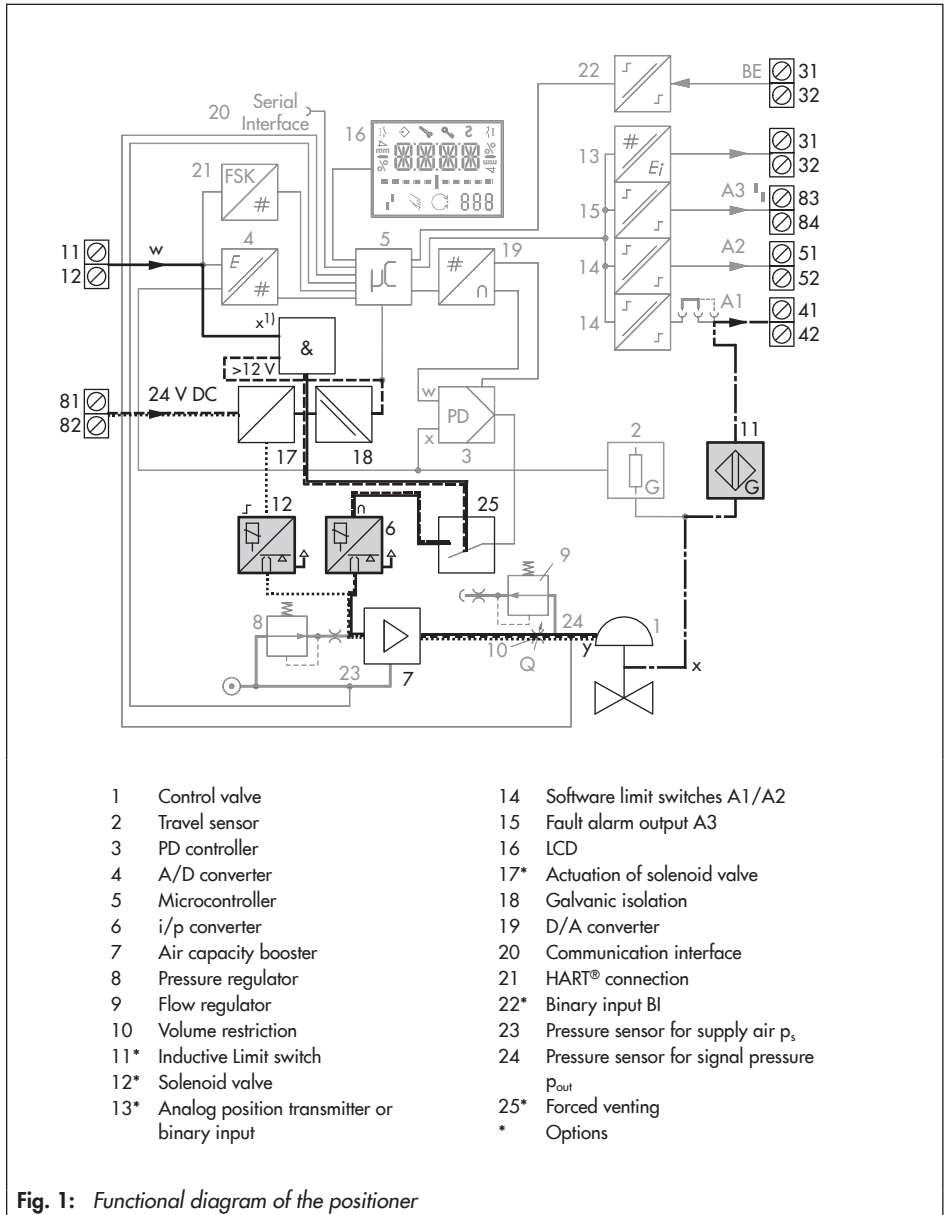

Fig. 1: Functional diagram of the positioner

i Note

The pneumatic output of the positioner can also be vented to the atmosphere over the software, e.g. by entering a corresponding set point. This procedure is not a safety-instrumented function.

3.2 Protection against unauthorized changes to the configuration

A change to the configuration cannot affect the safety-instrumented function nor cause it to be deactivated.

4 Mounting, connection and start-up

Refer to Mounting and Operating Instructions ► EB 8384-6 for details on how to mount, perform the electric and pneumatic connections as well as start up the positioner.

Only use the specified original mounting parts and accessories.

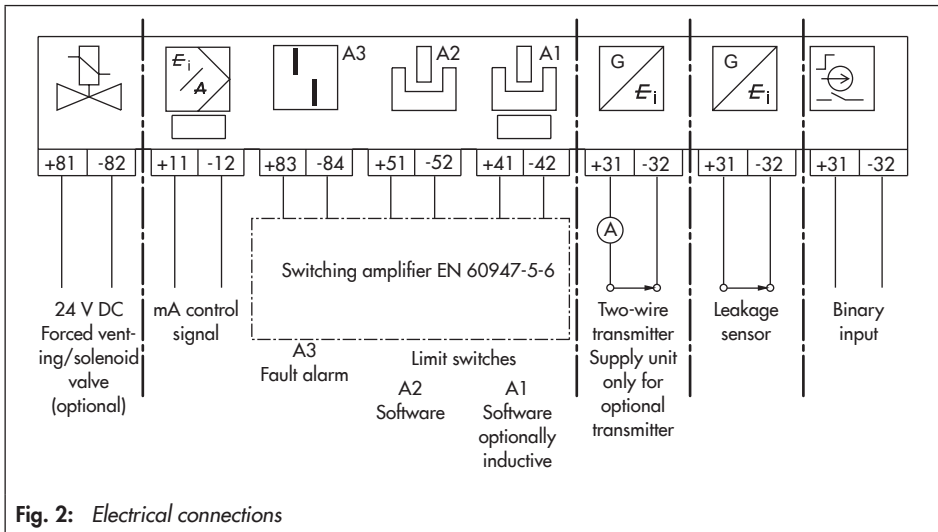

Fig. 2: Electrical connections

5 Required conditions

WARNING

Risk of malfunction due to incorrect selection or wrong installation and operating conditions.

→ Only use control valves in safety-instrumented systems if the necessary conditions in the plant are fulfilled. The same applies to the mounted positioner.

5.1 Selection

→ The required transit times of the control valve are observed.
The transit times to be implemented are determined by the process engineering requirements.

Tip

The minimum OPEN and CLOSE transit times can be read in Codes 40 and 41 after the positioner has been initialized.

→ The positioner is suitable for the prevailing ambient temperature.

Versions	Temperature range
All	-20 to +80 °C
With metal cable gland	-45 to +80 °C
The limits in the test certificates additionally apply to explosion-protected versions.	

→ The temperature limits are observed.

5.2 Mechanical and pneumatic installation

→ The positioner is mounted properly as described in the mounting and operating instructions and connected to the air supply.

Tip

Error codes 50 to 58 indicate incorrect attachment. For safety-instrumented systems, SAMSON recommends assigning the 'Failure' status to these errors to quickly recognize them when they occur (indicated by  on the display).

→ The maximum supply pressure does not exceed 7 bar.

Required conditions

- The pneumatic air supply meets the instrument air specifications.

Particle size and quantity	Oil content	Pressure dew point
Class 4	Class 3	Class 3
$\leq 5 \mu\text{m}$ and $1000/\text{m}^3$	$\leq 1 \text{ mg}/\text{m}^3$	$-20 \text{ }^\circ\text{C}$ or at least 10 K below the lowest ambient temperature to be expected



Tip

SAMSON recommends installing a supply pressure regulator/filter upstream of the device. For example, the SAMSON Type 4708 Supply Pressure Regulator with $5 \mu\text{m}$ filter cartridge can be used.

- The supply air line has a minimum inside diameter of 4 mm. Select the cross section and length of the line to ensure that the supply pressure at the device on supplying air does not fall below the minimum limit.
- The positioner is mounted as prescribed.
- The vent opening at the back of the positioner remains open when the positioner is installed on site.

5.3 Electrical installation

- The positioner is connected to the electric power supply properly as described in the mounting and operating instructions.
- Only cables whose outside diameters are suitable for the cable glands are used.
- The electrical cables in Ex i circuits comply with the data that planning was based on.
- The cable glands and cover screws are fastened tightly to ensure that the degree of protection is met.
- The installation requirements for the applicable explosion protection measures are observed.
- The special conditions specified in the explosion protection certificates are observed.

5.4 Operation

- When the optional inductive limit switch is used, Code 38 is set to YES.
- The inductive limit switch is adjusted mechanically to meet the specifications.

6 Proof testing

The proof test interval and the extent of testing lie within the operator's responsibility. The operator must draw up a test plan, in which the proof tests and the interval between them are specified. SAMSON recommends summarizing the requirements of the proof test in a checklist.

⚠ WARNING

Risk of dangerous failure due to malfunction in the event of emergency (actuator is not vented or the valve does not move to the fail-safe position).

Only use devices in safety-instrumented systems that have passed the proof test according to the test plan drawn up by the operator.

Regularly check the safety-instrumented function of the entire SIS loop. The test intervals are determined, for example on calculating each single SIS loop in a plant (PFD_{avg}).

6.1 Visual inspection to avoid systematic failure

To avoid systematic failure, inspect the positioner regularly. The frequency and the scope of the inspection lie within the operator's responsibility. Take application-specific influences into account, such as:

- Dirt blocking the pneumatic connections
- Corrosion (destruction primarily of metals due to chemical and physical processes)
- Material fatigue
- Aging (damage caused to organic materials, e.g. plastics or elastomers, by exposure to light and heat)
- Chemical attack (organic materials, e.g. plastics or elastomer, which swell, leach out or decompose due to exposure to chemicals)

ⓘ NOTICE

Risk of malfunction due to the use of unauthorized parts.

➔ *Only use original parts to replace worn parts.*

6.2 Function testing

Regularly check the safety-instrumented function according to the test plan drawn up by the operator.

Note

Record any positioner faults and e-mail (aftersaleservice@samsongroup.com) them to SAMSON.

Emergency venting by applying a mA signal to terminals 11/12 (control signal):

1. Supply the positioner with air within the permissible supply pressure range (max. 7 bar) which allows the valve to move to the maximum travel/angle of rotation.
 2. Connect an electric input signal >3.8 mA or >4.4 mA to the positioner (terminals 11/12), **depending on the emergency shutdown**.
 3. Switch the positioner to automatic mode (if it has not already been done).
 4. Set the input signal (terminals 11/12) over a local current source or over the control system in such a way that the valve moves to 50 % of its travel/angle of rotation.
-

Tip

The travel in automatic mode can be read at the positioner in Code 0.

5. Set the electric input signal **depending on emergency shutdown** to lower than 3.8 mA or 4.4 mA.
 6. This must cause the valve to move to its fail-safe position (terminals 11/12).
 7. Check whether the actuator is fully vented within the demanded time.
-

Tip

Connect a pressure gauge to check that the actuator has completely vented.

Emergency venting over solenoid valve (0 V signal to terminals 81/82):

1. Supply the positioner with air within the permissible supply pressure range (max. 7 bar) which allows the valve to move to the maximum travel/angle of rotation.

2. Connect an electric input signal >3.8 mA or >4.4 mA to the positioner (terminals 11/12), **depending on the emergency shutdown**.
 3. Supply the solenoid valve with a voltage >19 V DC (terminals 81/82).
 4. Set the input signal (terminals 11/12) over a local current source or over the control system in such a way that the valve moves to 50 % of its travel/angle of rotation.
-

**Tip**

The travel in automatic mode can be read at the positioner in Code 0.

5. Set the voltage to 0 V DC (terminals 81/82).
 6. Check whether the actuator is fully vented within the demanded time.
-

**Tip**

Connect a pressure gauge to check that the actuator has completely vented.

Emergency venting over forced venting (signal <12 V at terminals 81/82).

1. Supply the positioner with air within the permissible supply pressure range (max. 7 bar) which allows the valve to move to the maximum travel/angle of rotation.
 2. Connect an electric input signal >3.8 mA or >4.4 mA to the positioner (terminals 11/12), **depending on the emergency shutdown**.
 3. Supply the forced venting with a voltage >19 V DC (terminals 81/82).
 4. Set the input signal (terminals 11/12) over a local current source or over the control system in such a way that the valve moves to 50 % of its travel/angle of rotation.
-

**Tip**

The travel in automatic mode can be read at the positioner in Code 0.

5. Set the voltage to <12 V DC (terminals 81/82).
 6. Check whether the actuator is fully vented within the demanded time.
-

**Tip**

Connect a pressure gauge to check that the actuator has completely vented.

Proof testing

Safety-related end position monitoring

1. Supply the positioner with air within the permissible supply pressure range (max. 7 bar) which allows the valve to move to the maximum travel/angle of rotation.
2. Connect an electric input signal >3.8 mA or >4.4 mA to the positioner (terminals 11/12), **depending on the emergency shutdown**.
3. Switch the positioner to automatic mode (if it has not already been done).
4. Set the input signal (terminals 11/12) over a local current source or over the control system in such a way that the valve moves to 50 % of its travel/angle of rotation.
5. Set the input signal (terminals 11/12) over a local current source or over the control system in such a way that the valve moves to the end position.
6. Check whether a signal is issued at terminals 41/42 when the valve has reached the end position.

Proof test

A full stroke test must be performed as the proof test. The following value can be used for Proof Test Coverage to calculate PFD_{avg} :

PTC (Proof Test Coverage) = 92 % for a proof test

7 Maintenance and repair

Only perform the work on the positioner described in ► EB 8384-6.

! NOTICE

Safety-instrumented function will be impaired if repair work is performed incorrectly.

→ Only allow trained staff to perform service and repair work.

For devices operated in the low demand mode, a useful lifetime of 11 years (plus 1.5 years storage time) is confirmed by TÜV Rheinland® from the date of manufacture while taking into account the specific conditions of use specified in the Safety Manual and the Mounting and Operating Instructions.

The results of the proof test must be assessed and the maintenance scheduled based on it. In particular, after changes (e.g. signs of aging in elastomers, changed switching times or leakage etc.), it is essential that the manufacturer performs maintenance or repair work on the device.

MTC (Maintenance Coverage) > 99 %

8 Safety-related data and certificates

PSTC (Partial Stroke Test Coverage)	68 %
PTC (Proof Test Coverage)	92 %
MTC (Maintenance Coverage)	>99 %

Further safety-related data are listed in the following certificate.

Certificate



SIL/PL
Capability

www.tuv.com
ID: 040000000

No.: 968/V 1161.02/22

Product tested	Electro pneumatic positioners	Certificate holder	SAMSON AG Weismüllerstr. 3 60314 Frankfurt / Main Germany
-----------------------	-------------------------------	---------------------------	--

Type designation	see Revisionlist
-------------------------	------------------

Codes and standards	IEC 61508 Parts 1-2 and 4-7:2010
----------------------------	----------------------------------

Intended application	Safety Function: Safe venting (and safe indication of the end positions)
-----------------------------	--

The positioners are suitable for use in a safety instrumented system up to SIL 2 (low demand mode).

Under consideration of the minimum required hardware fault tolerance HFT = 1 the positioners may be used in a redundant architecture up to SIL 3 according to IEC 61508 and IEC 61511:2016 + AMD1:2017.

Specific requirements	The instructions of the associated Installation, Operating and Safety Manual shall be considered.
------------------------------	---

Summary of test results see back side of this certificate.

The issue of this certificate is based upon an evaluation in accordance with the Certification Program CERT FSP1 V1.0:2017 in its actual version, whose results are documented in Report No. 968/V 1161.02/22 dated 2022-08-25. This certificate is valid only for products, which are identical with the product tested.

TÜV Rheinland Industrie Service GmbH
Bereich Automation
Funktionale Sicherheit

Köln, 2022-09-08

Certification Body Safety & Security for Automation & Grid

Dipl.-Ing. (FH) Wolf Rückward

www.fs-products.com
www.tuv.com

 **TÜVRheinland**[®]
Precisely Right.

Holder: SAMSON AG
Weilmüllerstraße 3
60314 Frankfurt am Main
Germany

Product tested: Electropneumatic positioners
3730-0, 3730-1, 3730-2, 3730-3, 3730-4, 3730-5,
3730-6³, TROVIS SAFE 3730-6³

3731-3⁴, TROVIS SAFE 3731-3⁴, 3731-5

Results of Assessment

Hardware Fault Tolerance	HFT	0
Route of Assessment		$\Sigma_{i=1}^n / 1_{i0}$
Type of Sub-system		Type A
Mode of Operation		Low Demand Mode

Safe venting via slip-converter- all above mentioned types with or without

Lambda Dangerous Undetected ¹	λ_{DU}	9,58 E-08 / h	96 FIT
Average Probability of Failure on Demand ²	$PF_{DU}(T_i)$	4,19 E-04	

Safe venting via forced venting (3730-6, TROVIS SAFE 3730-6)

Lambda Dangerous Undetected ¹	λ_{DU}	9,58 E-08 / h	96 FIT
Average Probability of Failure on Demand ²	$PF_{DU}(T_i)$	4,19 E-04	

Safe venting solenoid valve (3730-2, 3730-3, 3730-4, 3730-5, 3730-6, TROVIS SAFE 3730-6)

Lambda Dangerous Undetected ¹	λ_{DU}	8,83 E-08 / h	88 FIT
Average Probability of Failure on Demand ²	$PF_{DU}(T_i)$	3,87 E-04	

Safe indication of the end positions (3730-1, 3730-2, 3730-3, 3730-4, 3730-5, 3730-6, TROVIS SAFE 3730-6)

Lambda Dangerous Undetected ¹	λ_{DU}	7,43 E-08 / h	74 FIT
Average Probability of Failure on Demand ²	$PF_{DU}(T_i)$	3,26 E-04	

¹ assumed Diagnostic Coverage DC = 0 %

² assumed Proof Test Interval $T_i = 1$ year

³ The types 3730-6 and TROVIS SAFE 3730-6 optionally have switch-off thresholds of < 3.8 mA or < 4.4 mA

⁴ The types 3731-3 and TROVIS SAFE 3731-3 optionally have switch-off thresholds of < 3.8 mA

Origin of values

The stated failure rates are the result of an FMECA with tailored failure rates for the design and manufacturing process.

Furthermore the results have been verified by qualification tests and field-feedback data of the last 5 years.

Failure rates include failures that occur at a random point in time and are due to degradation mechanisms such as ageing.

The stated failure rates do not release the end-user from collecting and evaluating application-specific reliability data.

Systematic Capability

The development and manufacturing process and the functional safety management applied by the manufacturer in the relevant lifecycle phases of the product have been audited and assessed as suitable for the manufacturing of products for use in applications with a maximum Safety Integrity Level of 3 (SIL 3).

Periodic Tests and Maintenance

The given values require periodic tests and maintenance as described in the Safety Manual.

The operator is responsible for the consideration of specific external conditions (e.g. ensuring of required quality of media, max. temperature, time of impact), and adequate test cycles.

Safety related modules / components

Type Designation	Description	Report-No.:	Certification Status
3730-0	Electropneumatic positioner	968/V 1161.00/20	Valid
3730-1	Electropneumatic positioner	968/V 1161.00/20	Valid
3730-2	Electropneumatic positioner	968/V 1161.00/20	Valid
3730-3	Electropneumatic positioner	968/V 1161.00/20	Valid
3730-4	Electropneumatic positioner	968/V 1161.00/20	Valid
3730-5	Electropneumatic positioner	968/V 1161.00/20	Valid
3730-6	Electropneumatic positioner	968/V 1161.00/20	Valid
TROVIS SAFE 3730-6	Electropneumatic positioner	968/V 1161.00/20	Valid
3731-3	Electropneumatic positioner	968/V 1161.00/20	Valid
TROVIS SAFE 3731-3	Electropneumatic positioner	968/V 1161.00/20	Valid
3731-5	Electropneumatic positioner	968/V 1161.00/20	Valid

Manufacturing locations

Type Designation	Description	Report-No.:	Certification Status
SAMSON AG	Weismüllerstraße 3 60314 Frankfurt am Main	968/V 1161.00/20	Valid
Samson Controls Solutions (Beijing) Co., Ltd.	Building 1, No. 15, Yong Chang Nan Lu, BDA, Beijing, 100176, P.R. China	968/V 1161.02/22	Valid

SAMSON AG
Weismüllerstraße 3
60314 Frankfurt am Main

TÜV Rheinland Industrie Service GmbH
Automation - Functional Safety (A-FS)
Am Grauen Stein
51105 Köln / Germany

Page 1 of 3

Safety Manual

Document No.	Description	Report-No.:	Certification Status
e8384mde 3730-0.pdf	Safety manual for type 3730-0	968/V 1161.00/20	Valid
e8384ode 3730-1.pdf	Safety manual for type 3730-1	968/V 1161.00/20	Valid
e8384qde 3730-2.pdf	Safety manual for type 3730-2	968/V 1161.00/20	Valid
e8384sde 3730-3.pdf	Safety manual for type 3730-3	968/V 1161.00/20	Valid
e8384nde 3730-4.pdf	Safety manual for type 3730-4	968/V 1161.00/20	Valid
e8384pde 3730-5.pdf	Safety manual for type 3730-5	968/V 1161.00/20	Valid
e8384rde 3730-6.pdf	Safety manual for type 3730-6	968/V 1161.00/20	Valid
e8384bde TROVIS SAFE 3730-6.pdf	Safety manual for type TROVIS SAFE 3730-6	968/V 1161.00/20	Valid
e8387yde 3731-3.pdf	Safety manual for type 3731-3	968/V 1161.00/20	Valid
e8387xde. TROVIS SAFE 3731-3.pdf	Safety manual for type TROVIS SAFE 3731-3	968/V 1161.00/20	Valid
e8387zde 3731-5.pdf	Safety manual for type 3731-5	968/V 1161.00/20	Valid

SAMSON AG
Weismüllerstraße 3
60314 Frankfurt am Main

TÜV Rheinland Industrie Service GmbH
Automation - Functional Safety (A-FS)
Am Grauen Stein
51105 Köln / Germany

Page 2 of 3

Revision List
referred to on Certificate No.: 968/V 1161.02/22
Certified Product: Electromagnetic positioners



Drawings

Document No.	Revision	Description	Report-No.:	Certification Status
GI03_1040_0002_8.pdf	8.a / 20.02.2015	Drawing for type 3730-0	968/V 1161.00/20	Valid
GI03_1040_0018_8.pdf	8.a / 20.02.2015	Drawing for type 3730-1	968/V 1161.00/20	Valid
GI03_1040_0013_11.pdf	11.a / 19.02.2015	Drawing for type 3730-2	968/V 1161.00/20	Valid
GI03_1040_0007_15.pdf	15.a / 18.11.2016	Drawing for type 3730-3	968/V 1161.00/20	Valid
GI03_1040_0014_11.pdf	11.a / 19.02.2015	Drawing for type 3730-4	968/V 1161.00/20	Valid
GI03_1040_0015_10.pdf	10.a / 20.02.2015	Drawing for type 3730-5	968/V 1161.00/20	Valid
GI01_1040_0347_6.pdf	6.a / 18.11.2016	Drawing for type 3730-6	968/V 1161.00/20	Valid
GI01_1040_0347_6.pdf	6.a / 18.11.2016	Drawing for type TROVIS SAFE 3730-6	968/V 1161.00/20	Valid
1170-2964_SWD_000_13_de.pdf	13 / 16.04.2019	Drawing for type 3731-3	968/V 1161.00/20	Valid
1170-2964_SWD_000_13_de.pdf	13 / 16.04.2019	Drawing for type TROVIS SAFE 3731-3	968/V 1161.00/20	Valid
1170-2964_SWD_000_13_de.pdf	13 / 16.04.2019	Drawing for type 3731-5	968/V 1161.00/20	Valid

The content of this Revision List has been agreed between Manufacturer and Certification Body.

Revision:

Date	Rev.	Description / Changes	Author
2020-05-04	1.0	Initial creation, based on Report-No.: 968/V 1161.00/20	JCz/A-FS
2022-08-17	2.0	Addition of manufacturing facility in P.R. China Report-No.: 968/V 1161.02/22	JCz/A-FS

SAMSON AG
 Weismüllerstraße 3
 60314 Frankfurt am Main

TÜV Rheinland Industrie Service GmbH
 Automation - Functional Safety (A-FS)
 Am Grauen Stein
 51105 Köln / Germany

SH 8384-6 EN



SAMSON AKTIENGESELLSCHAFT
Weismüllerstraße 3 · 60314 Frankfurt am Main, Germany
Phone: +49 69 4009-0 · Fax: +49 69 4009-1507
samson@samsongroup.com · www.samsongroup.com