

T 3017 EN

Type 42-37 Flow and Differential Pressure Regulator

Type 42-39 Flow and Differential Pressure or Pressure Regulator

Series 42 Self-operated Regulators



Application

Flow rate and differential pressure control or flow rate and pressure control in district heating systems or large heating networks · Differential pressure or pressure set points **0.1 to 5 bar** · Valves **DN 15 to 250**¹⁾ · Pressure rating **PN 16 to 40** · Suitable for liquids from **5 to 150 °C**¹⁾

The valve **closes** when the differential pressure or flow rate **rises**.

The regulators consist of a valve with adjustable restriction to adjust the flow rate and an actuator with two operating diaphragms.

The regulators limit the flow rate. The set point for the flow rate is adjusted at the valve. The set point for the differential pressure or downstream pressure is adjusted at the diaphragm actuator. The largest signal is always used to control the regulator.

Special features

- Low-noise, medium-controlled proportional regulator requiring little maintenance
- Nominal size DN 125 to 250 with fixed plug guide as standard, e.g. installation in riser pipes.
- Suitable for circuit water, water/glycol mixtures and air as well as liquids, provided they do not affect the characteristics of the operating diaphragm.
- Single-seated valve with a plug balanced by a stainless steel bellows or a balancing diaphragm.
- With internal overload protection (excess pressure limiter) in the actuator (Type 42-37)

Versions

Type 42-37 (Fig. 1) · Flow and differential pressure regulator for DN 15 to 250¹⁾ · For installation in the **return pipe** of a district heating transfer station

Consisting of a Type 2423 Globe Valve with integrated restriction and a Type 2427 Actuator · Flow rate set point adjustable at the valve · Differential pressure set point adjustable at the actuator

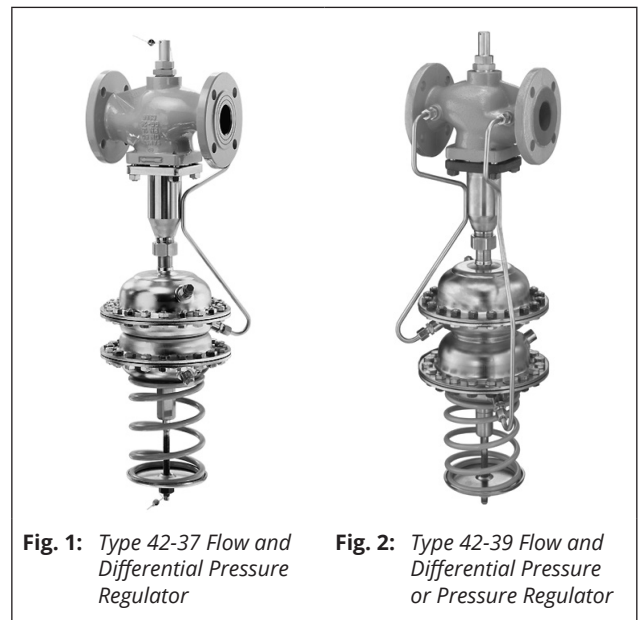

Fig. 1: Type 42-37 Flow and Differential Pressure Regulator

Fig. 2: Type 42-39 Flow and Differential Pressure or Pressure Regulator

Type 42-39 (Fig. 2) · Flow and differential pressure regulator or flow and pressure regulator in DN 15 to 250²⁾ · For installation in the **flow pipe** of a district heating transfer station

Consisting of a Type 2423 Globe Valve with integrated restriction and a Type 2429 Actuator · Flow rate set point adjustable at the valve · Differential pressure or pressure set point adjustable at the actuator

Accessories

Required accessories, such as compression-type fittings, needle valves, equalizing tanks and control lines, are listed in Data Sheet ▶ T 3095.

¹⁾ Other temperature ranges on request

²⁾ Valves for steam and gases on request · ANSI and JIS versions on request · Other temperature ranges on request · Version for mineral oils which do not affect the characteristics of the FKM diaphragm · Valves larger than DN 250 as Type 2334

Principle of operation

The medium flows through the valve in the direction indicated by the arrow. The areas released by the restriction (1.1) and the valve plug (3) determine the flow rate and the differential pressure Δp or the downstream pressure p_2 .

In a fully balanced valve, the position of the plug is not affected by pressure changes in the medium. The upstream pressure p_1 directly downstream of the restriction acts on the outside of the metal bellows or balancing diaphragm, while the downstream pressure p_2 acts on the inside of the bellows or balancing diaphragm (DN 65 to 250). As a result, the forces created by the differential pressure that act on the plug are eliminated.

The differential pressure Δp is converted by the bottom operating diaphragm (12.1) and the differential pressure created at the restriction based on the flow rate by the top operating diaphragm (12.3) into a positioning force. The largest signal is always used to control the regulator.

For example, if the differential pressure Δp rises, the positioning force at the bottom operating diaphragm (12.1) rises as well. This change in force causes the diaphragm stems (12.2 and 12.4) and the valve plug (3) to move in the closing direction. If the flow rate increases, the differential pressure at the restriction (1.1) increases and the pressure drops at the diaphragm chamber A. This change in differential pressure at the restriction only causes the diaphragm stem (12.4) and the valve plug (3) to move in the closing direction until the flow rate reaches the adjusted flow set point.

To control the flow rate, the pressure downstream of the restriction (1.1) is transmitted through a hole in the plug stem (7) and in the diaphragm stem (12.4) to the diaphragm chamber A. The high pressure of the flow is transmitted through the control line (18), attached to the regulator, to the diaphragm chamber B.

To control the differential pressure in the Type 42-37, the high pressure of Δp is transmitted through the control line, which is attached on the site of installation, to the diaphragm chamber D. The low pressure of Δp is equal to the high pressure of the flow rate and is transmitted also to the diaphragm chamber C.

To control the differential pressure in the Type 42-39, the high pressure of Δp is transmitted through the control line (19) to the diaphragm chamber D. The low pressure of Δp is transmitted over a control line (to be attached on assembling the regulator) to the diaphragm chamber C.

When Type 42-39 is used as a flow and pressure regulator, the pressure connection of the diaphragm chamber C remains open.

An overload protection (excess pressure limiter) (15) in the actuator protects the seat (2) and plug (3) from overload during exceptional operating conditions that could lead to valve or plant damage (see Table 1).

The principle of operation of the regulator balanced by a bellows or diaphragm only differs concerning the pressure balancing. Valves balanced by a diaphragm (DN 65 to 250) have a balancing diaphragm. The downstream pressure p_2 acts on the bottom of the diaphragm and the upstream pressure p_1 on the top of the diaphragm. As a result, the forces created by the upstream and downstream pressures acting on the valve plug are balanced out.

Legend for Fig. 4 and Fig. 3

1	Type 2423 Valve
1.1	Restriction for adjusting the flow rate set point
2	Seat
3	Plug
5	Metal bellows
7	Plug stem
11	Coupling nut
12	Type 2427/Type 2429 Actuator
12.1	Operating diaphragm
12.2	Diaphragm stem
12.3	Operating diaphragm
12.4	Diaphragm stem
14	Set point spring
15	Force limiter with internal excess pressure limiter (overload protection)
17	Set point adjuster for differential pressure
18, 19	Control lines
A, B, C, D	Diaphragm chambers

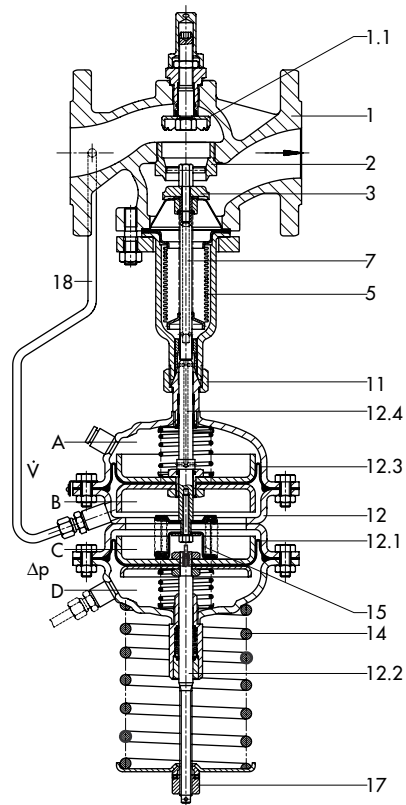

Fig. 3: Type 42-37 Flow and Differential Pressure Regulator (balanced by a bellows)

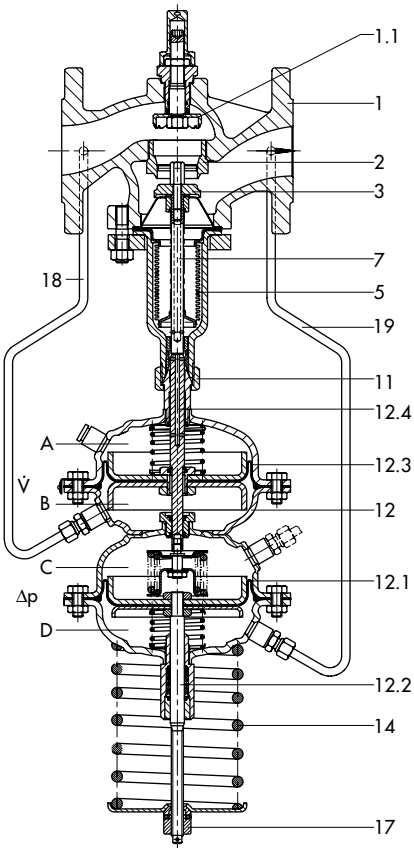

Fig. 4: Type 42-39 Flow and Differential Pressure or Pressure Regulator (balanced by a bellows)

Installing the regulators

Valve, actuator and control lines are delivered unattached.

Mount the actuator preferably after the valve is installed in the pipeline. It is connected to the bottom section of the valve with a coupling nut (11).

The following points must be observed:

- Install valves in horizontal pipelines.
- The direction of flow must match the arrow on the valve body.
- Install a strainer (e.g. SAMSON Type 2 NI) upstream of the valve.



Permissible mounting positions

- All valve sizes: install the actuator suspended downwards (see photo)
- DN 15 to 80 plus max. 120 °C: install the actuator either suspended or upright
- All valve sizes with fixed plug guide plus max. 120 °C: any position possible
- Steam applications: Always install actuator suspended downwards.

Special version

- With internal parts resistant to mineral oils
- Valve entirely of stainless steel (at least 1.4301)
- Liquids and vapors up to 220 °C
- ANSI/JIS version

Ordering text

Type 42-37 Flow and Differential Pressure Regulator
or
Type 42-39 Flow and Differential Pressure or Pressure Regulator

DN ...

Valve balanced by a bellows/diaphragm

Body material ...

PN ...

Differential pressure at the restriction 0.2/0.5 bar

Differential pressure or pressure set point range ... bar

Optionally, special version ...

Optionally, accessories ... (▶ T 3095)

Table 1: Technical data · Type 42-37 and Type 42-39

Type 2423 Valve · Balanced by a bellows		
Nominal size		DN 15 to 250
Pressure rating		PN 16, 25 or 40
Pressure at which internal excess pressure limiter responds (Type 42-37 only)	160 cm ²	1.2 bar
	320 cm ²	0.6 bar
Max. permissible temperature	Valve body	See pressure-temperature diagram in ► T 3000
	Actuator ¹⁾	With compensation chamber: liquids up to 220 °C Without compensation chamber: 150 °C
Differential pressure or pressure set point ranges		0.1 to 0.6 bar · 0.2 to 1 bar · 0.5 to 1.5 bar · 1 to 2.5 bar 2 to 5 bar ²⁾ · 4.5 to 10 bar ²⁾
Leakage class according to IEC 60534-4		≤0.05 % of K _{vs} coefficient
Conformity		CE
Type 2423 Valve · Balanced by a diaphragm		
Nominal size		DN 65 to 250
Pressure rating		PN 16, 25 or 40
Pressure at which internal excess pressure limiter responds (Type 42-37 only)	for 160 cm ²	1.2 bar
	320 cm ²	0.6 bar
	640 cm ²	0.3 bar
Max. permissible temperature	Valve body	150 °C
	Actuator ¹⁾	Liquids 150 °C
Differential pressure or pressure set point ranges		0.1 to 0.6 bar ³⁾ · 0.2 to 1 bar · 0.5 to 1.5 bar · 1 to 2.5 bar · 2 to 5 bar ²⁾
Leakage class according to IEC 60534-4		≤0.05 % of K _{vs} coefficient
Conformity		CE

¹⁾ Higher temperatures on request

²⁾ On request

³⁾ For DN 15 to 100 only

Table 2: K_{vs} coefficients, x_{FZ} values, flow rate set point ranges for water and max. permissible differential pressures Δp

Type 2423 Valve · Balanced by a bellows															
Nominal size DN	15	20	25	32	40	50	65	80	100	125	150	200	250		
Valve travel	10 mm						16 mm			22 mm					
K _{vs} coefficient	4	6.3	8	16	20	32	50	80	125	190	280	420	500		
x _{FZ} value	0.65	0.6	0.55		0.45	0.4		0.35				0.3			
Flow rate set point ranges for water in m ³ /h															
Differential pressure across restriction Δp _{restriction}	0.2 bar	0.05 to 2	0.15 to 3	0.25 to 3.5	0.4 to 7	0.6 to 11	0.9 to 16	2 to 28	3.5 to 35 ¹⁾	6.5 to 63	11 to 80	18 to 120	20 to 180	26 to 220	
	0.5 bar	0.15 to 3	0.25 to 4.5	0.4 to 5.3	0.6 to 9.5	0.9 to 16	2 to 24	3.5 to 40	6.5 to 55	11 to 90	18 to 120	20 to 180	26 to 260	30 to 300	
Max. perm. differential pressure Δp	25 bar						20 bar		16 bar		12 bar	10 bar			
Type 2423 Valve · Balanced by a diaphragm															
Nominal size DN	65	80	100	125	150	200	250								
Valve travel	15 mm						35 mm								
K _{vs} coefficient	50	80	125	250	380	650	800								
x _{FZ} value	0.4	0.35					0.3								
Flow rate set point ranges for water in m ³ /h															
Differential pressure across restriction Δp _{restriction}	0.2 bar	2 to 28		3.5 to 35 ¹⁾		6.5 to 63		11 to 120		18 to 180		20 to 320		26 to 350	
	0.5 bar	3.5 to 40		6.5 to 55		11 to 90		18 to 180		20 to 260		26 to 450		30 to 520	
Max. perm. differential pressure Δp	12 bar			10 bar		12 bar			10 bar						

¹⁾ 7 to 35 m³/h (160 cm² actuator), 7 to 40 m³/h (320 cm² actuator)

Differential pressure across the valve

The minimum required differential pressure Δp_{\min} across the valve is calculated as follows:

$$\Delta p_{\min} = \Delta p_{\text{restriction}} + \left(\frac{\dot{V}}{K_{VS}} \right)^2$$

Δp_{\min} Minimum differential pressure across the valve in bar
 $\Delta p_{\text{restriction}}$ Differential pressure created at the restriction for measuring the flow rate in the regulator
 \dot{V} Adjusted flow rate in m³/h
 K_{VS} Valve flow coefficient in m³/h

Table 3: Materials · Material numbers according to DIN EN

Type 2423 Valve · Balanced by a bellows					
Pressure rating	PN 16	PN 25	PN 16, 25 and 40		
Valve body	Cast iron EN-GJL-250	Spheroidal graphite iron EN-GJS-400-18-LT	Cast steel 1.0619	Cast stainless steel 1.4408	Forged stainless steel 1.4404 ¹⁾
Seat	1.4104, 1.4006			1.4404	
Plug	Up to DN 100	1.4104, 1.4006 ²⁾			1.4404
	DN 125 to 250	1.4301, 1.4404 with PTFE seal			
Plug stem	1.4301				
Metal bellows	1.4571 · DN 125 and larger: 1.4404				
Bottom section	P265GH			1.4571	
Body gasket	Graphite on metal core				
Type 2423 · Balanced by a diaphragm					
Pressure rating	PN 16	PN 25	PN 16, 25 and 40		
Valve body	Cast iron EN-GJL-250	Spheroidal graphite iron EN-GJS-400-18-LT	Cast steel 1.0619	Cast stainless steel 1.4408 ⁷⁾	-
Valve seat	Red brass ^{3) 4)}				
Plug (standard version)	Red brass ^{3) 5)} with EPDM soft seal, max. 150 °C or with PTFE soft seal, max. 150 °C				
Pressure balancing	Balancing cases made of sheet steel DD11 · EPDM balancing diaphragm, max. 150 °C or FKM, version with two balancing diaphragms				
Type 2427 and Type 2429 Actuators					
Diaphragm cases	1.0332			1.4301	
Diaphragm	EPDM ⁶⁾ with fabric reinforcement · Special version for mineral oils: FKM				
Guide bushing	DU bushing			PTFE	
Seals	EPDM/PTFE ⁶⁾				

¹⁾ DN 15, 25, 40 and 50 only

²⁾ Optionally with soft seal with standard K_{VS} coefficients

³⁾ Special version 1.4409

⁴⁾ DN 65 to 100: 1.4006

⁵⁾ DN 65 to 80: 1.4104, DN 100: 1.4006, with metal seal

⁶⁾ Special version for mineral oils: FKM

⁷⁾ DN 125 to 250 only

Application

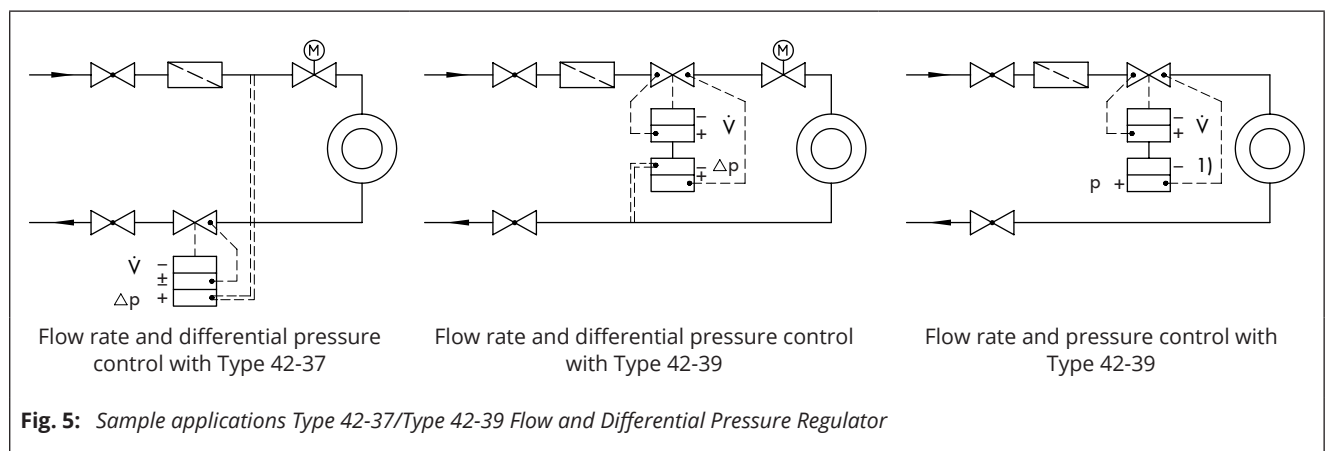
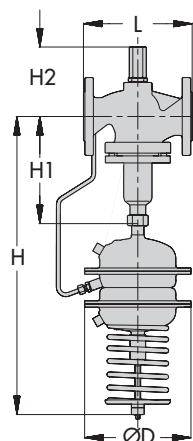

Fig. 5: Sample applications Type 42-37/Type 42-39 Flow and Differential Pressure Regulator

Dimensions

Dimensional drawing · Type 2423 Valve balanced by a bellows



Type 42-37/Type 42-39

Fig. 6: Regulator with Type 2423 Valve balanced by a bellows

Table 4: Dimensions in mm and weights · Type 2423 Valve **balanced by a bellows**

Nominal size	DN	15	20	25	32	40	50	65	80	100	125	150	200	250	
Overall length L		130	150	160	180	200	230	290	310	350	400	480	600	730	
Height H1		225						300		355	460	590	730		
Height H2	Other materials	115			150			175	180	200	250	280	400		
	Forged steel	113	-	130	-	170	176	-							
Set point ranges ³⁾															
0.1 to 0.6 bar	Height H ^{1) 5)}	675						770		825	-				
	Actuator	ØD = 225 mm, A = 160 cm ²						ØD = 285 mm, A = 320 cm ²		-					
	Weight ²⁾ , approx. kg	20.5	21	22	28.5	29	31.5	56	61	71	-				
0.2 to 1 bar	Height H ^{1) 5)}	675						770		825	1130	1160	1240		
	Actuator	ØD = 225 mm, A = 160 cm ² ⁴⁾						ØD = 285 mm, A = 320 cm ²		ØD = 285 mm, A = 320 cm ²					
	Weight ²⁾ , approx. kg	20.5	21	22	28.5	29	31.5	45	50	63	130	180	420	480	
0.5 to 1.5 bar	Height H ^{1) 5)}	705						780		835	1130	1160	1240		
	Actuator	ØD = 225 mm, A = 160 cm ² ⁴⁾						ØD = 285 mm, A = 320 cm ²		ØD = 285 mm, A = 320 cm ²					
	Weight ²⁾ , approx. kg	20.5	21	22	28.5	29	31.5	45	50	63	135	185	425	485	
1 to 2.5 bar	Height H ^{1) 5)}	705						780		835	1130	1160	1240		
	Actuator	ØD = 225 mm, A = 160 cm ²						ØD = 285 mm, A = 320 cm ²		ØD = 285 mm, A = 320 cm ²					
	Weight ²⁾ , approx. kg	20.5	21	22	28.5	29	31.5	45	50	63	135	185	425	485	
2 to 5 bar	Height H ^{1) 5)}	615						690		745	-				
	Actuator	ØD = 225 mm, A = 160 cm ²						ØD = 285 mm, A = 320 cm ²		ØD = 285 mm, A = 320 cm ²					
	Weight ²⁾ , approx. kg	20.5	21	22	28.5	29	31.5	45	50	63	-				

¹⁾ Type 42-39: add 50 mm to total height H.

²⁾ The weight applies to the version with the material specifications EN-GJL-250/PN 16 (GG-25). Add +10 % for spheroidal graphite iron EN-GJS-400-18-LT/PN 25, cast steel 1.0619/PN 40 and 1.4404/1.4408.

³⁾ Δp = 4.5 to 10 bar on request

⁴⁾ Optionally with 320 cm² actuator (DN 65 to 100). For regulators with double adapter Do2 (▶ T 3019) for DN 65 to 100, actuator 320 cm² recommended.

⁵⁾ Minimum clearance required to remove the actuator: +100 mm

Dimensional drawing · Type 2423 Valve balanced by a diaphragm

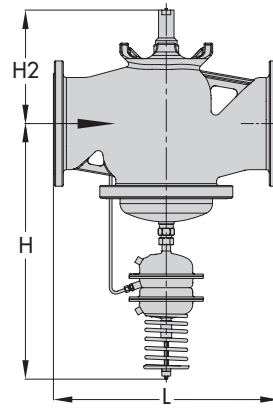

Type 42-37/Type 42-39

Fig. 7: Regulator with Type 2423 Valve, balanced by a diaphragm

Table 5: Dimensions in mm and weights · Type 2423 Valve **balanced by a diaphragm**

Nominal size	DN 65	DN 80	DN 100	DN 125	DN 150	DN 200	DN 250
Overall length L	290	310	350	400	480	600	730
Height H ²⁾	660		685	910	935	1020	
Height H2	195		220	295	325	345	375
Weight for PN 16 ¹⁾ in kg (approx.)							
Type 2423 Valve	34	39	49	65	85	248	268
Type 2427/2429 Actuator	16		27		35		

¹⁾ PN 25/40: +10 %

²⁾ Minimum clearance required to remove the actuator: +100 mm

